

NT-DINCH
SERRATION**NT-M**METRIC
SERRATION**High precision power chucks Ø 170 - 400 mm**

- Centrifugal force compensation
- Closed center
- 3 jaws
- proofline® chucks = fully sealed – low maintenance

**Application/customer benefits**

- For mid to large batch production / high speed machining and for fragile parts
- Fully sealed, ideal for dry machining of castings and forgings or if high pressure coolant is used

NT-D: Master jaws with INCH SERRATION (1/16" x 90°, 3/32" x 90°)**NT-M:** Master jaws with METRIC SERRATION (1.5 mm x 60°)
(suitable for japanese chuck top jaws)**Technical features**

- Centrifugal force compensation
- Constant gripping force with permanent grease lubrication
- Center bore for coolant and / or air
- Chuck body and internal parts case hardened
- **proofline® chucks** = fully sealed – low maintenance

Standard equipment

- 3 jaw chuck
- 1 set T-nuts and bolts
- 1 set soft top jaws

Ordering example

- 3 jaw chuck NT-D 215 / A6
- or
- 3 jaw chuck NT-M 260 / Z220

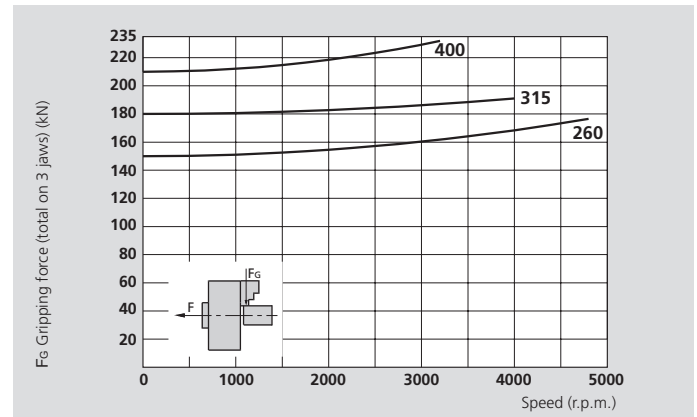
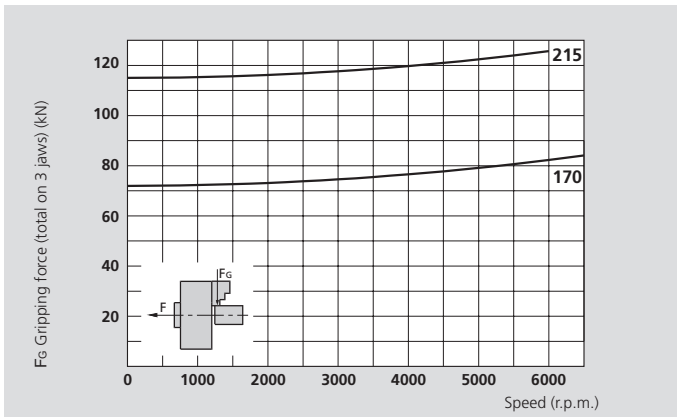
Actual gripping force diagrams

The data in the diagrams refer to 3 jaw chucks, newly maintained according to their service manuals using SMW-AUTOBLOK K67 grease. The static and dynamic gripping forces have been measured using standard soft top jaws, placed in a position not exceeding the outer diameter of the chuck.

△ Safety advice / danger of damage:

When using taller / heavier jaws and / or clamping on a bigger diameter reduce draw pull / rotating speed accordingly.

Technical data

SMW-AUTOBLOK Type		NT-D 170 NT-M 170	NT-D 215 NT-M 215	NT-D 260 NT-M 260	NT-D 315 NT-M 315	NT-D 400 NT-M 400
Number of jaws		3	3	3	3	3
Radial jaw stroke	mm	3.6	4.6	5	6.3	7
Axial piston stroke	mm	17	22	24	30	33
Max. draw pull*	kN	30	42	55	65	75
Max. gripping force*	kN	72	112	150	180	210
Max. speed	r.p.m.	6500	6000	4800	4000	3200
Weight (without top jaws)	kg	13	25	40	68	112
Moment of inertia	kg·m ²	0.048	0.146	0.34	0.84	2.15
Recommended actuating cylinders	Type	SIN-S 100	SIN-S 100 / 125	SIN-S 125 / 150	SIN-S 125 / 150	SIN-S 150 / 175

* For internal clamping reduce the draw pull by 30%.



on request:
• Tooling Standard
• Parts Catalog



• SMW-AUTOBLOK
• 438

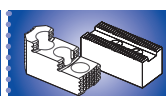

• SMW-AUTOBLOK
• 440



• SMW-AUTOBLOK
• 297

High precision power chucks Ø 170 - 400 mm

- Centrifugal force compensation
- Closed center
- 3 jaws
- proofline® chucks = fully sealed – low maintenance

NT-D

INCH
SERRATION

NT-M

METRIC
SERRATION

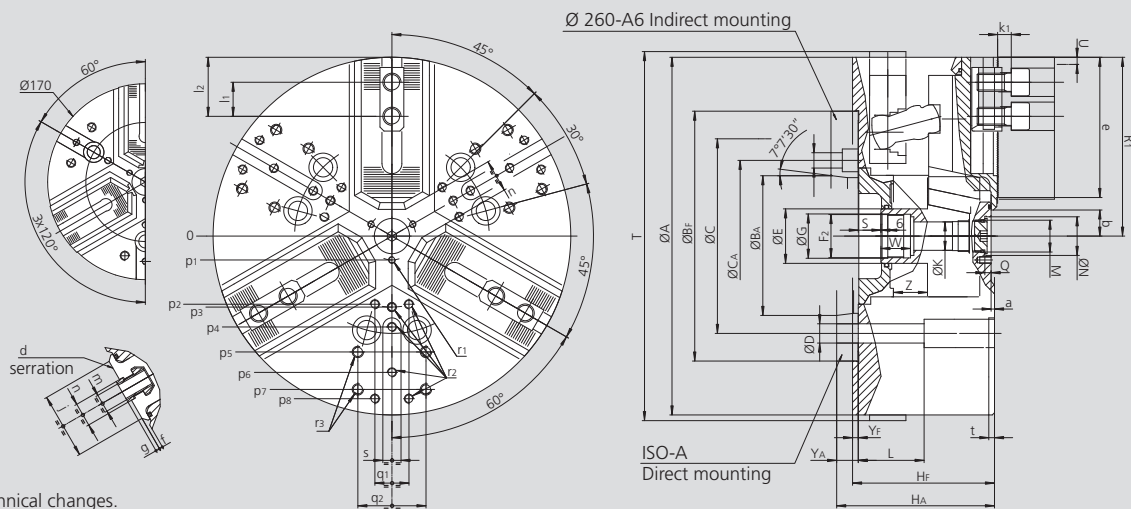

Subject to technical changes.
For more detailed information please ask our customer service.

SMW-AUTOBLOK Type			NT-D 170 NT-M 170		NT-D 215 NT-M 215		NT-D 260 NT-M 260			NT-D 315 NT-M 315		NT-D 400 NT-M 400	
Mounting			Z140	A5	Z170	A6	Z220	A6	A8	Z220	A8	Z300	A11
	A	mm	172		216		262			315		390	
	Bf/BAH6	mm	140	82.563	170	106.375	220	106.375	139.719	220	139.719	300	196.869
	C	mm	104.8		133.4		171.4	-	171.4	171.4		235	
	CA	mm	-	-	-	-	-	133.4	-	-	-	-	-
	D	mm	11.5		13.5		17	13.5	17	17		21	
	E	mm	32		42		48			48		75	
	F2	mm	M24 x 2		M32 x 1.5		M38 x 1.5			M38 x 1.5		M60 x 1.5	
	G H8	mm	25		33		39			39		61	
	Hf/HA	mm	92	102	104	116	118	137	132	125	139	149	164
	K	mm	18.5		20		25			25		48	
	L	mm	43		52		58			58		74	
	M	mm	M10 x 1		M22 x 1.5		M28 x 1.5			M28 x 1.5		M52 x 1.5	
	N H9	mm	15		24		34			34		60	
	Q	mm	4.5		5.5		5.5			5.5		9	
Chuck open	R1	mm	86.5		108		131			157.5		195	
Max. / min.	S	mm	20 / 3		19 / -3		22 / -2			20 / -10		33 / 0	
Chuck fully closed	T	mm	175		220		-			-		-	
Radial jaw stroke	U	mm	3.6		4.6		5			6.3		7	
	W	mm	22		26		26			26		38	
	Yf/YA	mm	5	15	5	17	5	24	19	5	19	6	21
Max. / min.	Z	mm	17 / 0		22 / 0		24 / 0			30 / 0		33 / 0	
	a	mm	3		3		3			3		3	
Min.	b	mm	8.5		12		14			16.5		31	
Min.	c	mm	9		13		14			16		38	
NT-D serration	d	inch	1/16" x 90°		1/16" x 90°		1/16" x 90°			1/16" x 90°		3/32" x 90° (1)	
NT-M serration	d	mm	1.5 x 60°		1.5 x 60°		1.5 x 60°			1.5 x 60°		1.5 x 60°	
	e	mm	67		82		102			123		144	
	f	mm	3		3		3			3		6	
	g	mm	2.5		2.5		2.5			3.5		3.5	
	j	mm	34		46		48			58		63	
	k1	mm	10		11		12			12		14	
NT-D	l1	mm	16.5		23		30			30		38	
NT-M	l1	mm	20		25		30			30		38	
	l2	mm	43 / 24		53 / 33		70 / 41			84 / 43		98 / 54	
NT-D	m	mm	M10		M12		M12			M16		M20	
NT-M	m	mm	M10		M12		M12			M16		M20	
NT-D	n	mm	14		17		17			21		25.5	
NT-M	n	mm	12		14		16			21		22	
	p1	mm	16		16		21			21		37.5	
	p2	mm	-		-		-			60		80	
	p3	mm	38		49		55			62.5		83	
	p4	mm	-		80		70			80		110	
	p5	mm	65		80		102			102		140	
	p6	mm	70		-		102			120		155	
	p7	mm	-		-		-			135		170	
	p8	mm	-		-		-			-		170	
	q1	mm	-		-		-			30		36	
	q2	mm	36		45		60			60		80	
	r1	mm	M5 / 7		M5 / 8		M6 / 10			M6 / 10		M6 / 12	
	r2	mm	M6 / 14		M8 / 17		M8 / 17			M8 / 17		M10 / 19	
	r3	mm	M8 / 17		M8 / 17		M10 / 19			M10 / 19		M12 / 22	
	s	mm	16		16		16			16		20	
	t	mm	5		5		5			5		5	

(1) Serration 1/16 x 90° on request.