

# FRS

Self centering clamping  
TONGUE & GROOVE

## Lever chuck Ø 215 - 365 mm

- Self centering clamping
- Large through hole
- proofline® chucks = fully sealed – low maintenance



### Application/customer benefits

- Self centering clamping of flange or shaft type workpieces where the reference is not a center but the O.D. of the workpiece
- The through hole of the chuck allows to swallow the workpiece if needed
- Due to its high rigidity against torsion the chuck can be used for turning as well as for milling

### Technical features

- For O.D. clamping only
- Large through hole
- TONGUE & GROOVE base jaws
- Pull-down to axial datum
- Permanent grease lubrication
- Rigid design against torsion
- **proofline® chucks** = fully sealed - low maintenance

### Standard equipment

3 jaw chuck  
Mounting bolts

### Ordering example

3 jaw chuck FRS 285 Z 220

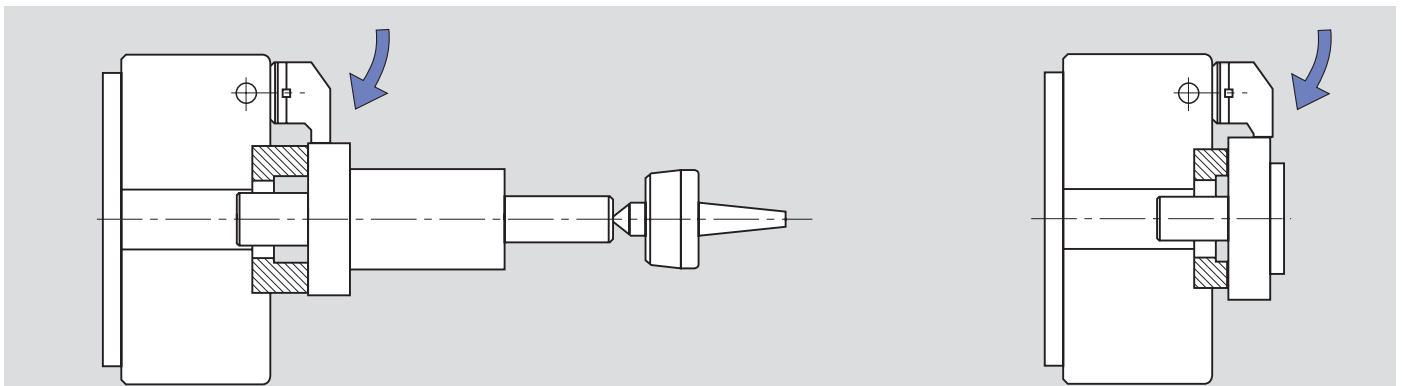

#### ■ FRS self centering chuck with pull-down

The pull-down of the chuck pulls the workpiece against the workstop.  
The large bore allows the workpiece to be swallowed.

## Technical data

SMW-AUTOBLOK Type		FRS 215	FRS 285	FRS 365
Angular jaw stroke	deg.	6°	6°	6°
Radial jaw stroke at distance h	mm	6.3	7.3	8.4
Wedge stroke	mm	22	26	31
Max. draw pull	kN	45	70	110
Max. gripping force at distance h	kN	100	150	240
Max. speed*	r.p.m.	4500	3500	2500
Weight (plain back without top jaws)	kg	30	62	120
Moment of inertia	kg·m <sup>2</sup>	0.17	0.65	2
Recommended actuating cylinders	Type	SIN-S 100 - 125	SIN-S 125 - 150	SIN-S 150 - 200

\* The above maximum speed is allowed with standard weight / height top jaws and applying the full draw pull only. For more informations please contact SMW-AUTOBLOK.



SMW-AUTOBLOK  
444

SMW-AUTOBLOK  
438

SMW-AUTOBLOK  
297

# Lever chuck Ø 215 - 365 mm

# FRS

- Self centering clamping
- Large through hole
- proofline® chucks = fully sealed – low maintenance

Self centering clamping  
TONGUE & GROOVE

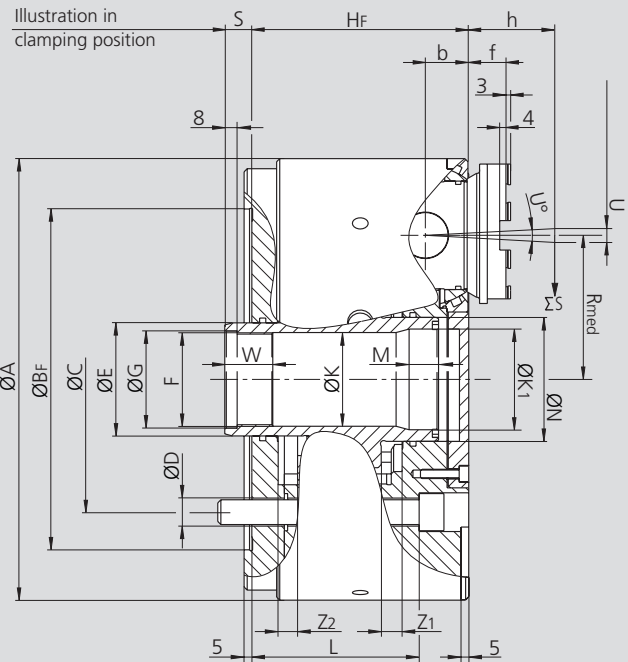
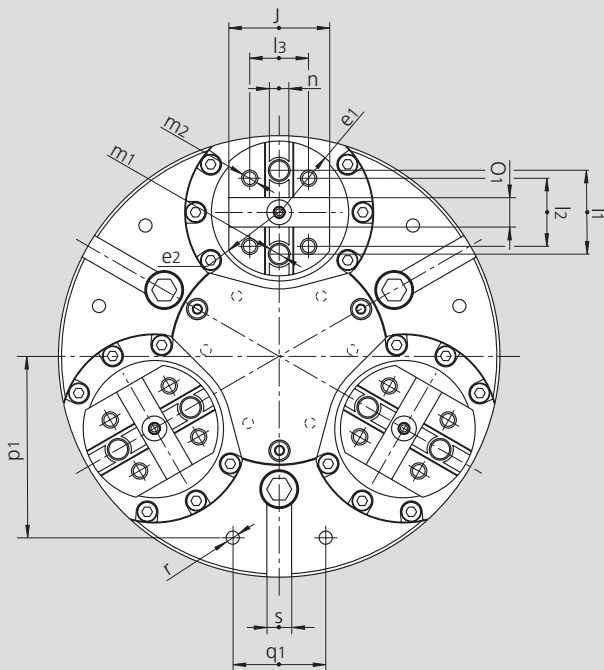

Subject to technical changes.  
For more detailed information please ask our customer service.

SMW-AUTOBLOK Type		FRS 215	FRS 285	FRS 365	
	<b>A</b>	mm	215	285	365
	<b>Bf</b> H6	mm	170	220	300
	<b>C</b>	mm	133.4	171.4	235
	<b>D</b>	mm	M12	M16	M20
	<b>E</b>	mm	50	73	79
	<b>F</b>	mm	M42 x 1.5	M60 x 1.5	M68 x 2
	<b>G</b> H8	mm	43	61	69
	<b>HF</b>	mm	120	140	168
Through hole	<b>K</b>	mm	40	60.5	60.5
	<b>K1</b>	mm	-	65	75
	<b>L</b>	mm	95	108	123
	<b>M</b>	mm	-	19	23.8
	<b>N</b>	mm	52	80	90
	<b>Rmed</b>	mm	67	93	120
At middle stroke - clamping position	<b>S</b>	mm	15.4	17.5	24.8
Min. / max.	<b>S</b>	mm	4 / 26	4 / 30	9 / 40
Angular jaw movement	<b>U</b> °	deg.	6°	6°	6°
Radial stroke at distance <b>h</b> <sup>(1)</sup>	<b>U</b>	mm	6.3	7.3	8.4
	<b>W</b>	mm	30	31	30
	<b>Z1</b>	mm	11.4	13.5	15.8
	<b>Z2</b>	mm	10.6	12.5	15.2
	<b>b</b>	mm	22	28	34
	<b>e1</b>	mm	37.5	46	50
	<b>e2</b>	mm	33	41	50
Reference height	<b>f</b>	mm	18	24	21
	<b>h</b>	mm	38	42	46
	<b>j</b>	mm	55	65	70
	<b>l1</b>	mm	38	54	63.5
	<b>l2</b>	mm	32	44	48
	<b>l3</b>	mm	32	38	48
Thread / depth	<b>m1</b>	mm	M12 / 16	M16 / 20	M16 / 20
Thread / depth	<b>m2</b>	mm	M10 / 14	M12 / 19	M12 / 19
	<b>n</b> h8	mm	7.94	12.7	12.7
	<b>o1</b> H7	mm	12.68	19.03	19.03
	<b>p1</b>	mm	80	117	150
	<b>q1</b>	mm	45	60	80
Thread / depth	<b>r</b>	mm	M8 / 17	M10 / 19	M12 / 22
	<b>s</b> H8	mm	16	16	20

<sup>(1)</sup> Calculated at **h** distance from the chuck's face (where normally the clamping takes place).