

TSF-RM

TSR-RM

Self centering
Floating jaws

Self centering
Rigid jaws

Quick jaw change pull-down chucks Ø 170 - 530 mm

- Active pull-down
- Quick jaw change with pallets
- Tongue & groove pallets - 3 jaws

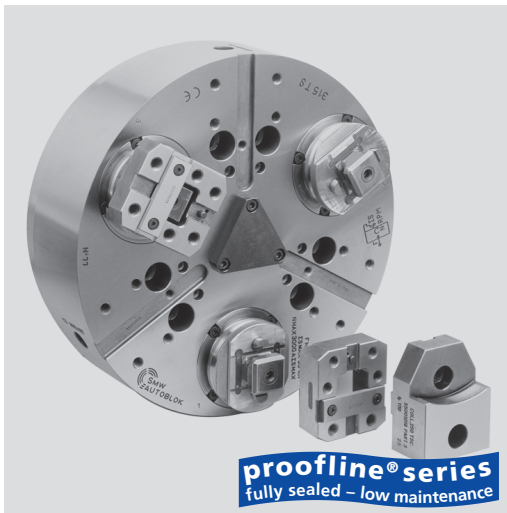

Application/customer benefits

- Quick jaw change via pallets for quick setup
- Clamping of workpieces with highest demand for **parallelism**
- **Highest productivity** with long maintenance intervals
- Constant grip force and long lifetime ensure **constant quality of workpieces**

TSF-RM: Floating base jaws to clamp raw and / or easy deformed workpieces (6-point-contact)

TSR-RM: Rigid base jaws for precise clamping on premachined diameters

Technical features

- For O.D. clamping only
- Active pull-down
- Precise quick-jaw-change via pallets
- Centrifugal force compensation
- Central bore for coolant and / or air
- Permanent grease lubrication
- **proofline® chucks**
= fully sealed - low maintenance

Standard equipment

3 jaw chuck
Key
Mounting bolts

Ordering example

3 jaw chuck TSF-RM 210/A6
or
3 jaw chuck TSR-RM 315/Z220

TSF-RM / TSR-RM

Quick jaw change with pallets

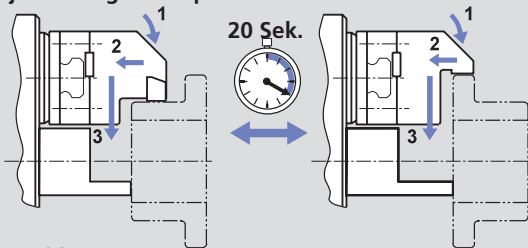

Principle of function:

- 1 pre-clamping - 2 active pull-down - 3 clamping
- For O.D. clamping only.

TSF-RM / TSR-RM

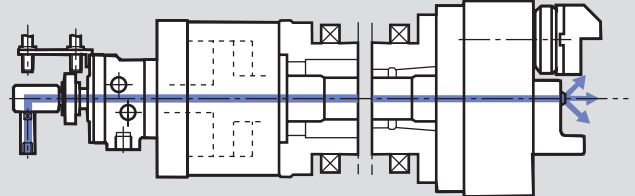

- TSF-RM and TSR-RM chucks operated with a SIN-S cylinder with central bore for air sensing and / or coolant flush.

TSF-RM

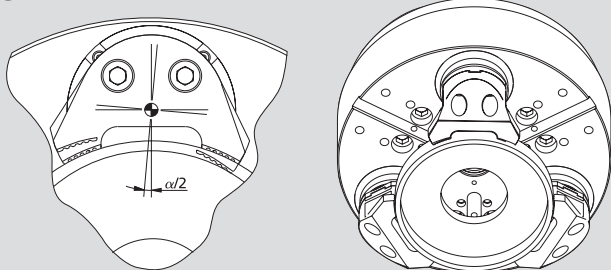

TSF-RM: Floating jaws to clamp raw / easy deformed workpieces quick jaw change with pallets with 6-point-contact.

TSR-RM

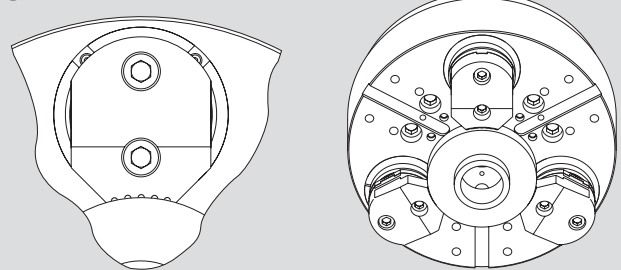

TSR-RM: Rigid jaws for precise clamping on premachined diameters with 3-point-contact, quick jaw change with pallets.

Technical data

SMW-AUTOBLOK Type		TSF-RM 170	TSF-RM 210	TSF-RM 250	TSF-RM 315	TSF-RM 400	TSF-RM 530
		TSR-RM 170	TSR-RM 210	TSR-RM 250	TSR-RM 315	TSR-RM 400	TSR-RM 530
Angular jaw stroke U°	deg.	5.2°	5.2°	4.9°	4.9°	4.7°	4.7°
Radial jaw stroke at distance h	mm	5.3	6.3	7	7	7.5	7.5
Pull down movement (standard)	mm	0.1	0.1	0.1	0.1	0.2	0.2
Axial piston stroke	mm	21	25	25	25	30	30
Max. draw pull**	kN	18	25	40	40	50	60
Max. gripping force at distance h **	kN	44	60	96	96	120	150
Max. speed*	r.p.m.	5000	4500	3800	3000	2200	1800
Weight (plain back without top jaws)	kg	15	27	41	66	115	196
Moment of inertia	kg-m ²	0.06	0.16	0.34	0.83	2.3	7
Recommended actuating cylinders	Type	SIN-S 85	SIN-S 100	SIN-S 125	SIN-S 125	SIN-S 150	SIN-S 150-175

* The above maximum speed is allowed with standard weight / height top jaws and applying the full draw pull only. For more informations please contact SMW-AUTOBLOK.

**For internal clamping reduce the draw pull by 30%.



on request:
Tooling Standard
Parts Catalog

QUICK CHANGE PALLETS

SMW-AUTOBLOK
172

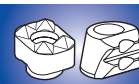

SMW-AUTOBLOK
444



SMW-AUTOBLOK
438

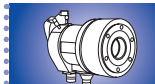

SMW-AUTOBLOK
297

Quick jaw change pull-down chucks Ø 170 - 530 mm

- Active pull-down
- Quick jaw change with pallets
- Tongue & groove pallets - 3 jaws

TSF-RM

Self centering
Floating jaws

TSR-RM

Self centering
Rigid jaws

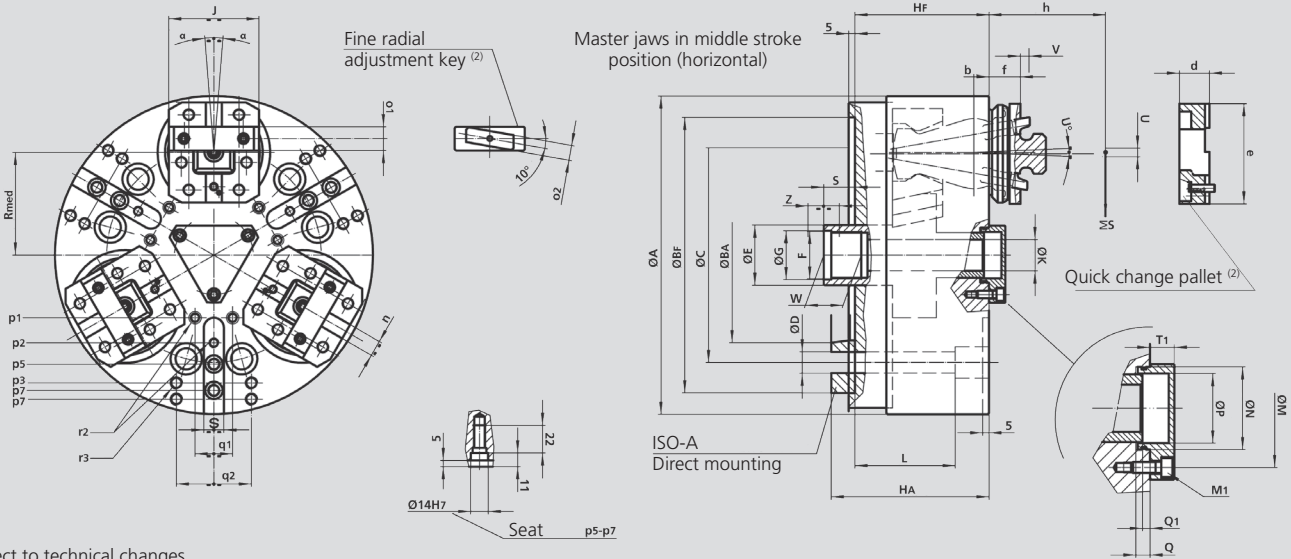

Subject to technical changes.
For more detailed information please ask our customer service.

4

SMW-AUTOBLOK Type			TSF-RM 170 TSR-RM 170		TSF-RM 210 TSR-RM 210		TSF-RM 250 TSR-RM 250		TSF-RM 315 TSR-RM 315		TSF-RM 400 TSR-RM 400		TSF-RM 530 TSR-RM 530			
Mounting			Z140	A5	Z160	A6	Z170	A6	Z220	A8	Z220	A8	Z300	A11	Z380	A15
	A	mm	173				212		254		315		390		535	
	Bf/BA H6	mm	140	82.563	160	106.375	170	106.375	220	139.719	220	139.719	300	196.869	380	285.775
	C	mm	104.8		133.4		133.4		171.4		171.4		235		330.2	
	D	mm	11.5		13.5		13.5		17		17		21		25	
	E	mm	36				38		48		48		75		75	
	F	mm	M28 x 1.5				M32 x 1.5		M38 x 1.5		M38 x 1.5		M60 x 1.5		M60 x 1.5	
	G H8	mm	29				33		39		39		61		61	
	Hf/HA	mm	83	98	83	100	100	117	107	126	107	126	127	148	132	155
Through hole	K	mm	14				18		25		25		52		52	
	L	mm	56				82		80		80		74		77	
	M	mm	36				42		63		63		90		90	
Thread / depth	M1	mm	M5 / 13				M6 / 11		M6 / 12		M6 / 12		M8 / 17		M8 / 17	
	N H8	mm	28				34		44		44		75		75	
	P	mm	23				28.5		37		37		66		66	
	Q	mm	6				5.5		7.5		7.5		9		9	
At middle stroke	Q1	mm	3				2		4		4		4		4	
At middle stroke	Rmed	mm	55				64		82		107		130		190	
At middle stroke	S	mm	18				20		25		25		25		20	
Radial stroke	T1	mm	10				13		13		13		15		15	
Radial stroke	U°	deg.	5.2°				5.2°		4.9°		4.9°		4.7°		4.7°	
Radial stroke ⁽¹⁾ @ h	U	mm	5.3				6.3		7		7		7.5		7.5	
Pull-down s/d (option)	V	mm	0.1				0.1		0.1		0.1		0.2		0.2	
	W	mm	25				25		25		25		25		25	
Axial piston stroke	Z	mm	21				25		25		25		30		30	
Only TSF-RM max.	α	deg.	±2°				±2°		±1.5°		±1.5°		±1.5°		±1.5°	
	b	mm	9				10		12		12		12		12	
	d	mm	18				22		24		24		30		30	
	e	mm	60				75		80		80		105		105	
	f	mm	24				25		25		25		28.5		28.5	
Reference height	h	mm	50				60		70		70		80		80	
	j	mm	55				65		72		72		100		100	
	n h8	mm	7.94				7.94		12.7		12.7		12.7		12.7	
	o1 H7	mm	12.68				12.68		19.03		19.03		19.03		19.03	
	o2 h7	mm	9				9		12		12		12		12	
	p1	mm	-				30		50		60		(*)		(*)	
	p2	mm	35				-		70		80		(*)		(*)	
	p3	mm	65				80		102		102		(*)		(*)	
	p4	mm	-				-		-		135		(*)		(*)	
	p5	mm	-				87		87		-		(*)		(*)	
	p7	mm	-				-		108		108		(*)		(*)	
	q1	mm	-				8		30		30		(*)		(*)	
	q2	mm	36				45		60		60		(*)		(*)	
Thread / depth	r2	mm	M6 / 12				M6 / 12		M8 / 15		M8 / 15		(*)		(*)	
Thread / depth	r3	mm	M8 / 17				M8 / 17		M10 / 19		M10 / 19		(*)		(*)	
	s	mm	16				16		16		16		20		20	

⁽¹⁾ Calculated at **h** distance from the chuck's face (where normally the clamping takes place).

* For chuck Ø 400-530 please ask for customer drawing.

⁽²⁾ SMW-AUTOBLOK 172: General catalog.