

BHD-FC

BHM-FC

High precision power chuck Ø 165 - 630 mm

INCH
SERRATION

METRIC
SERRATION

- Centrifugal force compensation
- Large through-hole
- 3 jaws



Application/customer benefits

- For open center or partial open center clamping
- Large through-hole
- Compensation of centrifugal force for high speed
- Clamping of easily deformed parts with low gripping force, maintained to high speed

BHD-FC: Master jaws with INCH SERRATION (1/16" x 90°, 3/32" x 90°)

BHM-FC: Master jaws with METRIC SERRATION (1.5 mm x 60°) (Ø 165 to 400 mm) (suitable for Japanese jaws)

Technical features

- Gripping force transmission via wedge hook
- Centrifugal force compensation by means of counter balance weights for minimum loss of gripping force at high speed
- Case hardened body (up to Ø 315) to assure greatest precision and long chuck life

Standard equipment

- 3-jaw chuck
- 1 set T-nuts with bolts
- 1 set soft top jaws
- Mounting bolts

Ordering example

- 3-jaw chuck BHD-FC 210 / A6
- or
- 3-jaw chuck BHM-FC 250 / Z220

Actual gripping force diagrams

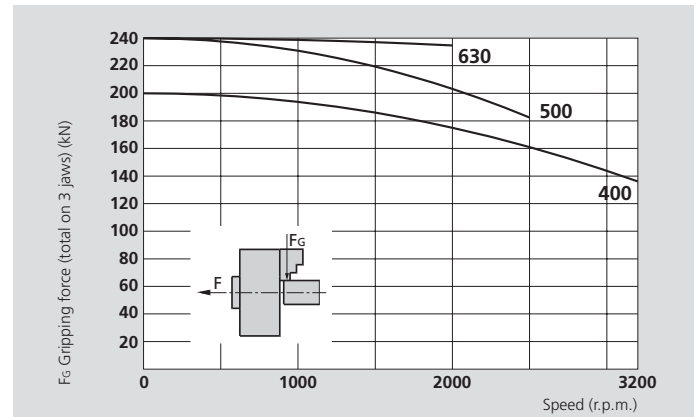
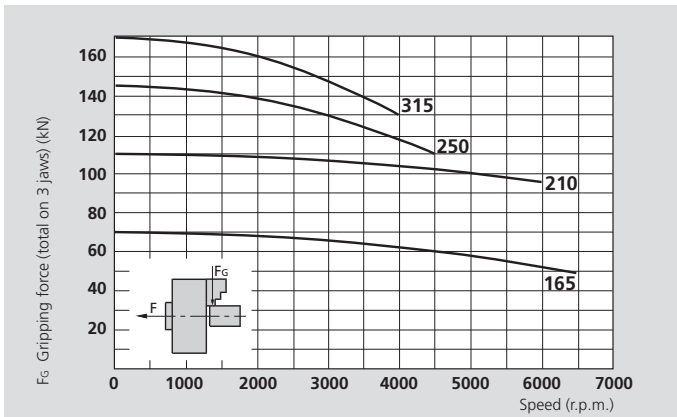

The data in the diagrams refer to 3-jaw chucks, newly maintained according to their service manuals using SMW-AUTOBLOK K67 grease. The static and dynamic gripping forces have been measured using standard soft top jaws, placed in a position not exceeding the outer diameter of the chuck.

⚠ Safety advice / danger of damage:

When using taller / heavier jaws and / or clamping on a bigger diameter reduce draw pull / rotating speed accordingly.

Technical data

SMW-AUTOBLOK Type		BHD-FC 165 BHM-FC 165	BHD-FC 210 BHM-FC 210	BHD-FC 250 BHM-FC 250	BHD-FC 315 BHM-FC 315	BHD-FC 400 BHM-FC 400	BHD-FC 500	BHD-FC 630
Number of jaws		3	3	3	3	3	3	3
Through-hole	mm	45	52	66	95	118	125	165
Radial jaw stroke	mm	3.2	4	5	5	6.5	9	9
Axial piston stroke	mm	15	19	24	24	31	34	34
Max. draw pull*	kN	25	38	50	60	70	100	100
Max. gripping force*	kN	70	110	145	170	200	240	240
Max. speed	r.p.m.	6500	6000	4500	4000	3200	2500	2000
Weight (without top jaws)	kg	11	21	32	50	95	160	335
Moment of inertia	kg·m ²	0.042	0.13	0.29	0.67	2	5.2	18
Recommended actuating cylinders	SIN-S	100	100 / 125	125 / 150	125 / 150	150 / 175	150 / 175 / 200	175 / 200
	VNK-T2 / VSG	102-46	130-52	150-67	225-95	320-127	320-127	450 / 165
Id.No. BHD-FC 3 jaws (Center mounting)		77154316	77154321	77154325	77154331	77154340	77154350	77154363
Id.No. BHM-FC 3 jaws (Center mounting)		77154616	77154621	77154625	77154431	77154640	-	-

* For internal clamping reduce the draw pull by 30%.



SMW-AUTOBLOK
466



SMW-AUTOBLOK
468



SMW-AUTOBLOK
327

High precision power chuck Ø 165 - 630 mm

- Centrifugal force compensation
- Large through-hole
- 3 jaws

BHD-FC

INCH
SERRATION

BHM-FC

METRIC
SERRATION

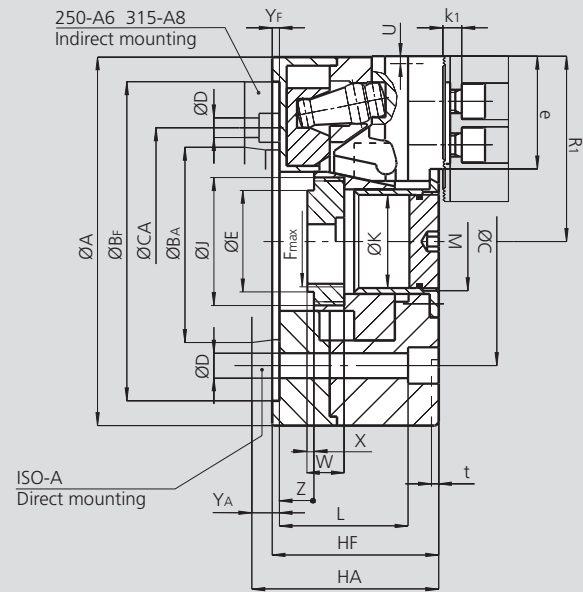
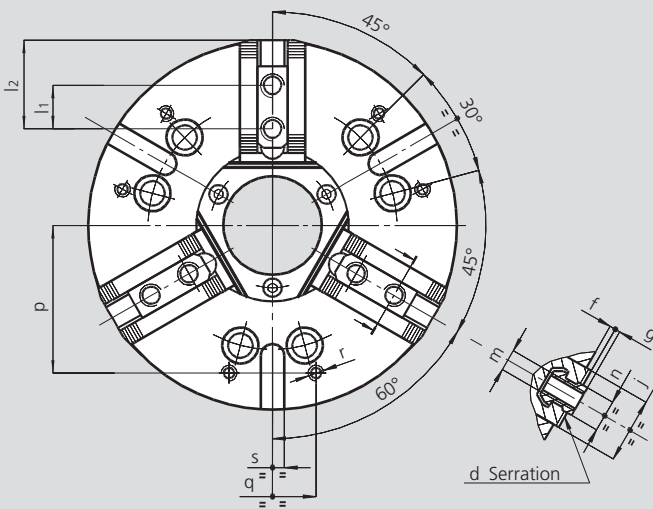

Subject to technical changes.
For more detailed information please ask our customer service.

SMW-AUTOBLOK Type		BHD-FC 165 BHM-FC 165		BHD-FC 210 BHM-FC 210		BHD-FC 250 BHM-FC 250			BHD-FC 315 BHM-FC 315			BHD-FC 400 BHM-FC 400		BHD-FC 500 -		BHD-FC 630 -		
Mounting		Z140	A5	Z170	A6	Z220	A6	A8	Z300	A8	A11	Z300	A11	Z380	A15	Z380	A15	
	A	mm	168	210	250			315			390		510		630			
	Bf/BA H6	mm	140	82.563	170	106.375	220	106.375	139.719	300	139.719	196.869	300	196.869	380	285.775	380	285.775
	C	mm	104.8		133.4		171.4	-	171.4	235	-	235	235	330.2		330.2		
	CA	mm	-	-	-	-	133.4	-	-	171.4	-	-	-	-	-	-	-	
	D	mm	11.5		13.5		17	13.5	17	21	17	21	21	25		25		
	E	mm	58		67		78			111			140		148		198	
	F/Fmax	mm	M52 x 1.5		M60 x 1.5		M72 x 1.5			M105 x 2			M130 x 2		M135 x 2		M175 x 2	
	J	mm	M60 x 1.5		M72 x 1.5		M88 x 1.5			M120 x 2			M145 x 2		M160 x 2		M195 x 2	
	Hf/HA	mm	90	100	100	112	115	134	129	120	145	136	143	158	160	177	160	177
	K	mm	45		52		66			95			118		125		165	
	L	mm	72		83		89			72			115		129		129	
	M	mm	M47 x 1.5		M54 x 1.5		M68 x 2			M98 x 2			M120 x 2		-	-	-	
Chuck open	R1	mm	84		105.5		127.5			158			195		255		315	
Jaw stroke	U	mm	3.2		4		5			5			6.5		9		9	
	W	mm	23		24		26			28			46		25		30	
	X	mm	5		4		6			6			17		3		5	
Max. / min.	Yf/YA	mm	5	15	5	17	5	24	19	5	30	21	6	21	6	23	6	23
	Z	mm	15 / 0		19 / 0		24 / 0			24 / 0			31 / 0		37 / 3		37 / 3	
BHD-FC ser.	d	inch	1/16" x 90°		1/16" x 90°		1/16" x 90°			1/16" x 90°			3/32" x 90°		3/32" x 90°		3/32" x 90°	
BHM-FC ser.	d	mm	1.5 x 60°		1.5 x 60°		1.5 x 60°			1.5 x 60°			1.5 x 60°		-		-	
	e	mm	49.5		66		77.5			93			116.5		152		192	
	f	mm	5		4		4			4			5		10		10	
	g	mm	2.5		2.5		3.5			3.5			3.5		3.5		3.5	
	j	mm	30		36		45			45			62		62		62	
	k1	mm	10		11		12			12			14		16		16	
BHD-FC	l1	mm	16.5		23		30			30			34		38		38	
BHM-FC	l1	mm	20		25		30			30			34		-		-	
Max. / min.	l2	mm	41 / 23		56 / 33		62 / 43			78 / 43			90 / 49		129 / 53		167 / 53	
BHD-FC	m	mm	M10		M12		M16			M16			M20		M20		M20	
BHM-FC	m	mm	M10		M12		M12			M16			M20		-		-	
BHD-FC	n h8	mm	14		17		21			21			25.5		25.5		25.5	
BHM-FC	n h8	mm	12		14		16			21			22		-		-	
	p	mm	65		80		102			125			150		160		200	
	q	mm	36		45		60			100			80		100		100	
	r	mm	M8		M8		M10			M10			M12		M12		M12	
	s H9	mm	16		16		16			20			20		20		20	
	t	mm	4.5		5		5			5			5		5		5	