

Besides our standard range, we offer special solutions for your applications

Example: Special expanding mandrel, sleeve design, on spindle and tailstock side for screw rotors

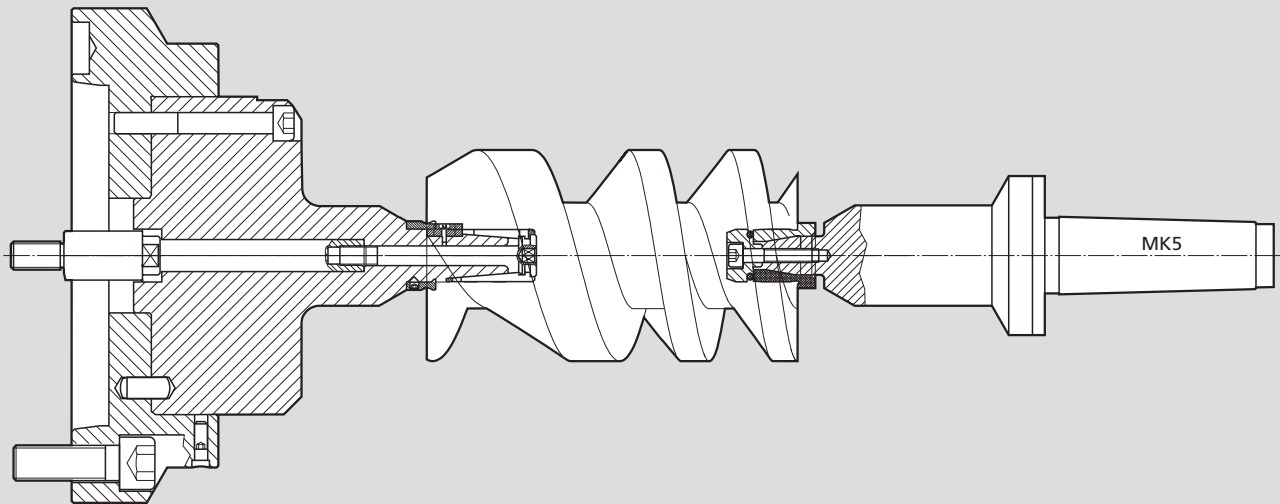

Example: Special mandrel segment design for tubes

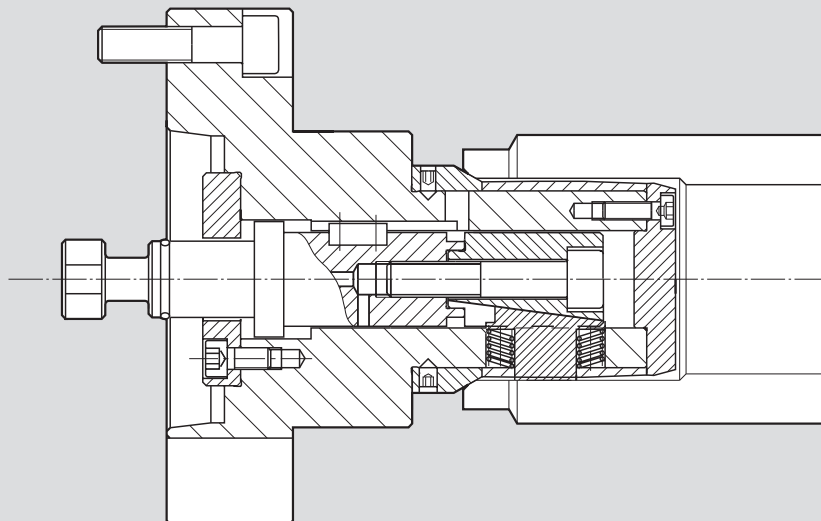

Example: Special expanding mandrel, double taper design with retractable stop, for clamping of stators

