

# TEF-C

Self centering  
Floating jaws

# TER-C

Self centering  
Rigid jaws

## High precision pull-down 2+2+2 equalising

Ø 260 - 850 mm

- Active pull-down
- Tongue & groove
- 6 jaws 2+2+2

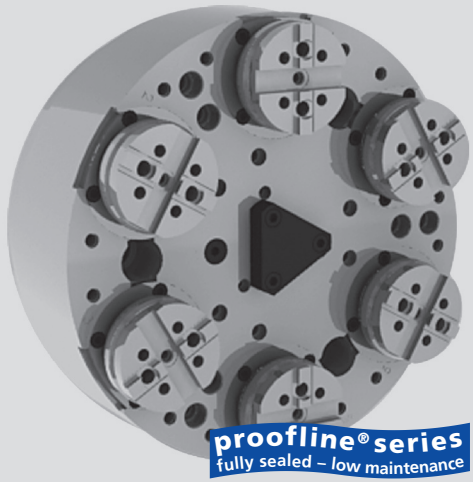

### Application/customer benefits

- Clamping of thin walled workpieces
- Suitable for OP 10 or unique clamping applications
- Low radial deformation with 2+2+2 clamping
- Constant grip force and long lifetime ensure **constant quality of workpieces**
- Low profile, ideal for machines with limited Z axis stroke

### Technical features

- 6 jaw design
- Active pull-down
- Floating base jaws for 12 point contact
- Centrifugal force compensation
- TONGUE & GROOVE base jaws
- Central bore for coolant and / or air
- Permanent grease lubrication
- **proofline® chucks = fully sealed - low maintenance**

### Standard equipment

6 jaw chuck  
Mounting bolts

### Ordering example

6 jaw chuck  
TEF-C 260 / A8

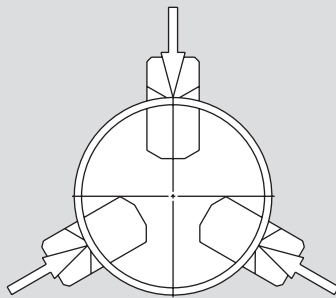

0 ≈ x

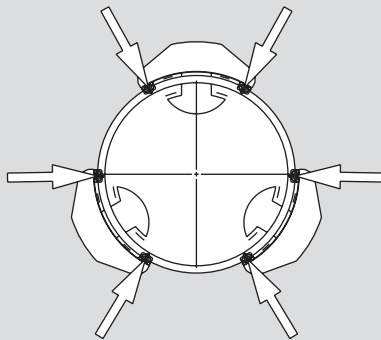

0 ≈ x/4

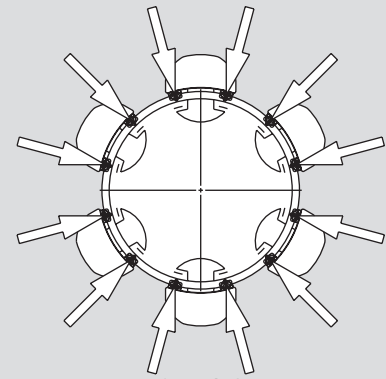

0 ≈ x/16

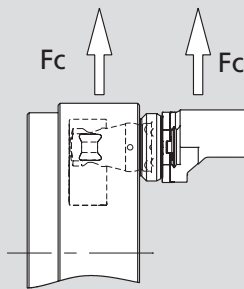

Very high centrifugal force compensation for very high speed.

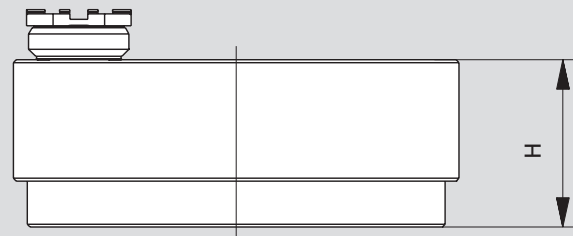

Very low profile and little limitation of the Z axis ideal for high production machines like the inverted spindle and frontal spindle lathes.

## Technical data

SMW-AUTOBLOK Type		TEF-C 260	TEF-C 320	TEF-C 400	TEF-C 530	TEF-C 650	TEF-C 850
		TER-C 260	TER-C 320	TER-C 400	TER-C 530	TER-C 650	TER-C 850
Angular jaw stroke U°	deg.	5.2°	4.9°	4.9°	4.7°	4.7°	5°
Radial jaw stroke at distance h	mm	5.4	6	7	7.6	7.5	9.8
Angular compensation jaw stroke max.	deg.	±2.4°	±2.2°	±2.2°	±2.1°	±1.5°	±2.25°
Radial compensation at distance h max.	mm	±2.5	±2.7	±3.2	±3.5	±2	±4.5
Pull down movement (standard)	mm	0.1	0.1	0.1	0.2	0.8	0.4
Axial piston stroke	mm	24	29	29	35	35	37
Max. draw pull**	kN	18	25	40	50	60	100
Max. gripping force at distance h**	kN	44	60	96	120	120	180
Max. speed*	r.p.m.	4200	3500	2500	1800	1200	1200
Weight (plain back without top jaws)	kg	39	68	118	234	370	770
Moment of inertia	kg·m <sup>2</sup>	0.33	0.85	2.5	8.4	20	71
Recommended actuating cylinders	Type	SIN-S 100	SIN-S 100	SIN-S 125	SIN-S 125	SIN-S 150	SIN-S 200

\* The above maximum speed is allowed with standard weight/height top jaws and applying the full draw pull only. For more informations please contact SMW-AUTOBLOK.

\*\* For internal clamping reduce the draw pull by 30%.

# High precision pull-down 2+2+2 equalising

Ø 260 - 850 mm

- Active pull-down
- Tongue & groove
- 6 jaws 2+2+2

## TEF-C

Self centering  
Floating jaws

## TER-C

Self centering  
Rigid jaws

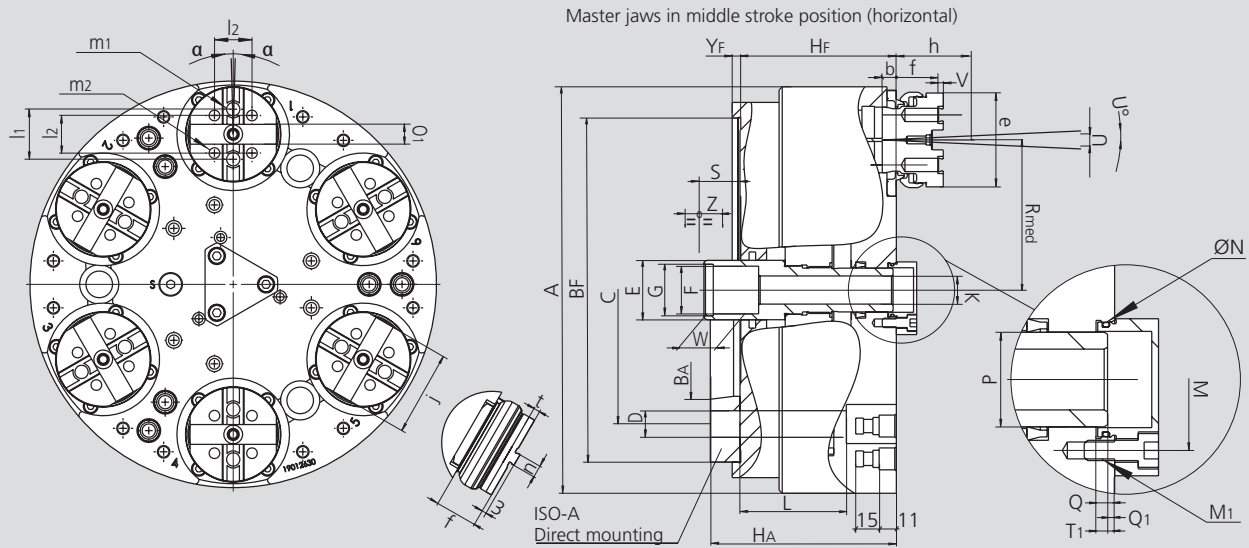

Subject to technical changes.  
For more detailed information please ask our customer service.

SMW-AUTOBLOK Type			TEF-C 260		TEF-C 320		TEF-C 400		TEF-C 530		TEF-C 650		TEF-C 850	
			TER-C 260		TER-C 260		TER-C 400		TER-C 530		TER-C 650		TER-C 850	
Mounting			Z220	A8	Z280	A11	Z300	A11	Z380	A15	Z380	A15	Z520	A20
	<b>A</b>	mm	260		320		404		530		650		850	
	<b>BF/BA H6</b>	mm	220	139.719	280	196.869	300	196.869	380	285.775	380	285.775	520	412.775
	<b>C</b>	mm	171.4		235		235		330.2		330.2		463.6	
	<b>D</b>	mm	17		21		21		26		26		27	
	<b>E</b>	mm	38		48		48		75		75		100	
	<b>F</b>	mm	M32 x 1.5		M38 x 1.5		M38 x 1.5		M60 x 1.5		M60 x 1.5		M80 x 2	
	<b>G H8</b>	mm	33		39		39		61		61		81	
	<b>Hf/HA</b>	mm	100	119	115	136	122	143	142	165	157	180	180	205
Through hole	<b>K</b>	mm	18		25		25		52		52		75	
	<b>L</b>	mm	68		84		94		107		107		145	
	<b>M</b>	mm	42		63		63		75		75		*	
Thread / depth	<b>M1</b>	mm	M6 / 11		M6 / 11		M6 / 11		M8 / 16		M8 / 16		M8 / 16	
	<b>N H8</b>	mm	34		44		44		75		75		150	
	<b>P</b>	mm	28		36		36		65		65		100	
	<b>Q</b>	mm	5.5		7.5		7.5		9		9		18.5	
At middle stroke	<b>Q1</b>	mm	5		5.5		5.5		6.5		10.5		5	
At middle stroke	<b>Rmed</b>	mm	96		113		152		200		260		345	
At middle stroke	<b>S</b>	mm	23.1		23.5		18.3		36.3		25.5		22.6	
	<b>T1</b>	mm	13		13		13		15		12		*	
Radial stroke	<b>U°</b>	deg.	5.2°		4.9°		4.9°		4.7°		4.7°		5°	
Radial stroke <sup>(1)</sup>	<b>U</b>	mm	5.4		6		7		7.6		7.5		9.8	
Pull-down s/d.	<b>V</b>	mm	0.1		0.1		0.1		0.2		0.8		0.4	
	<b>W</b>	mm	25		30		30		26		26		30	
Axial piston stroke	<b>Z</b>	mm	24		29		29		35		35		37	
	<b>α</b>	deg.	±2°**		±1.5°**		±1.5°**		±1.5°**		±1°**		±1.3°**	
	<b>b</b>	mm	9		10		12		12		12		12.4	
	<b>e</b>	mm	60		75		80		105		105		127	
	<b>f</b>	mm	27		33		33		32		32		46	
Reference height	<b>h</b>	mm	50		60		70		80		80		100	
	<b>j</b>	mm	55.2		65.2		72.2		100.2		100.2		116.2	
	<b>l1</b>	mm	32		38		44.4		63.5		63.5		63.5	
	<b>l2</b>	mm	24		32		36		48		48		54	
Thread / depth	<b>m1</b>	mm	M10 / 16		M12 / 18		M12 / 18		M16 / 20		M16 / 20		M20 / 25	
Thread / depth	<b>m2</b>	mm	M8 / 14		M10 / 14		M10 / 14		M12 / 17		M12 / 17		M16 / 24	
	<b>n h8</b>	mm	7.94		7.94		12.7		12.7		12.7		12.7	
	<b>o1 H7</b>	mm	12.68		12.68		19.03		19.03		19.03		19.03	
	<b>t</b>	mm	4		4		4		7		4		7	
	<b>YF</b>	mm	5		5		6		6		6		6	

\* Please ask for chuck drawing.

\*\* TEF-C only.

<sup>(1)</sup> Calculated at **h** distance from the chuck's face (where normally the clamping takes place).