

- Electronic safety control unit
- For Big Bore chucks
- Proximity switch for pressure and stroke control signals

Universal, electronic micro-processor compact control unit for Big Bore chucks in 1/2" / 3/4" design

- All safety systems integrated
- Easy installation - no other devices needed
- Can be connected to all common voltages
- LCD display in English language
- Quick chuck actuation by 1/2" / 3/4" pneumatic parts
- To be actuated by an external signal

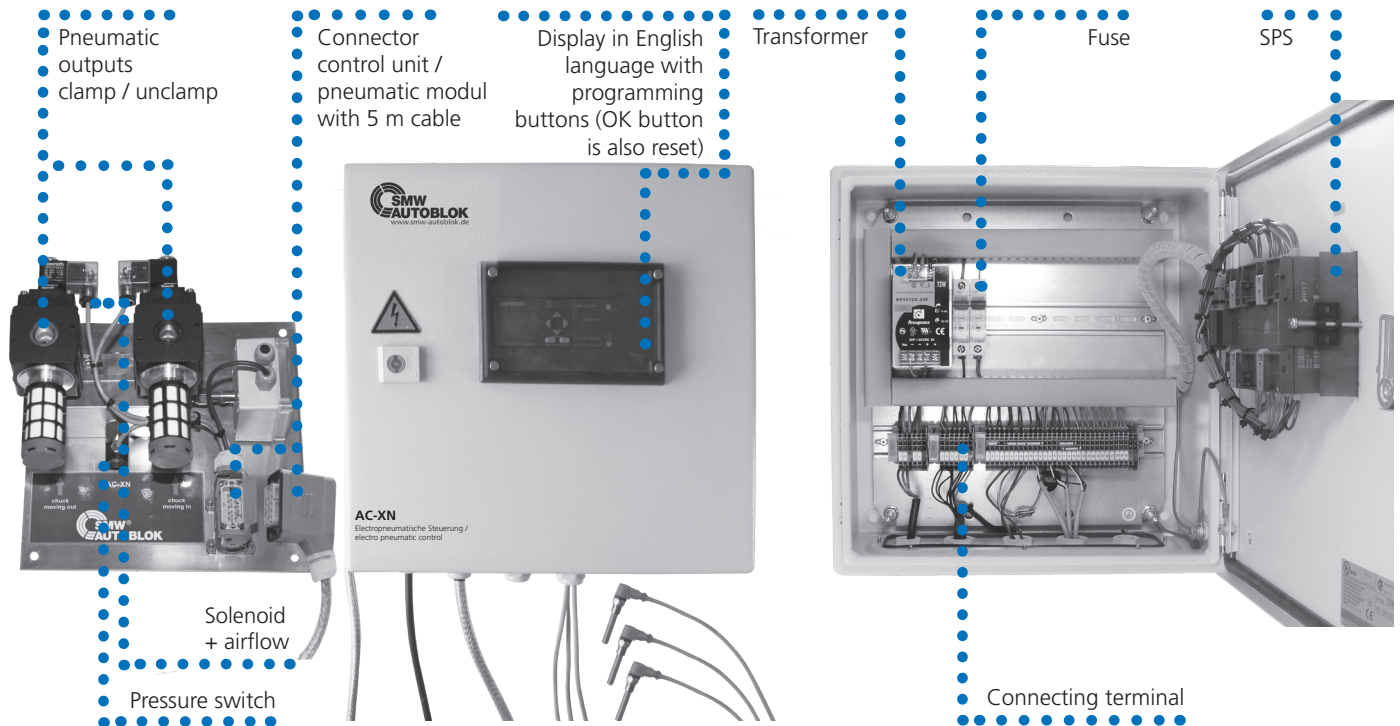

Accessories:

Foot pedal F2
with 4 m cabel
Id. No. 013324

Proximity switch for pressure and stroke control signals M8 x 1
Id. No. 203500

Air service unit 1/2"
Id. No. 192074
Air service unit 3/4"
Id. No. 199790

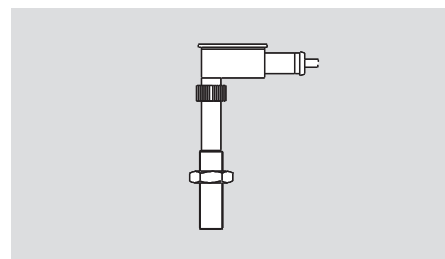

Order review:

| | |
|----------------------------------|----------------|
| Control unit AC-XN complete 1/2" | Id. No. 203491 |
| Control unit AC-XN complete 3/4" | Id. No. 203490 |

Standard equipment:

Control unit
W x H x D = 380 x 380 x 220 mm

Pneumatic module 1/2" or 3/4"
W x H x D = 300 x 300 x 130 mm

3 pcs. Proximity switch M8 x 1
(Id. No. 203500) included in supply range

- Pneumatic diagram
- Electric diagram

Electric connection AC-XN

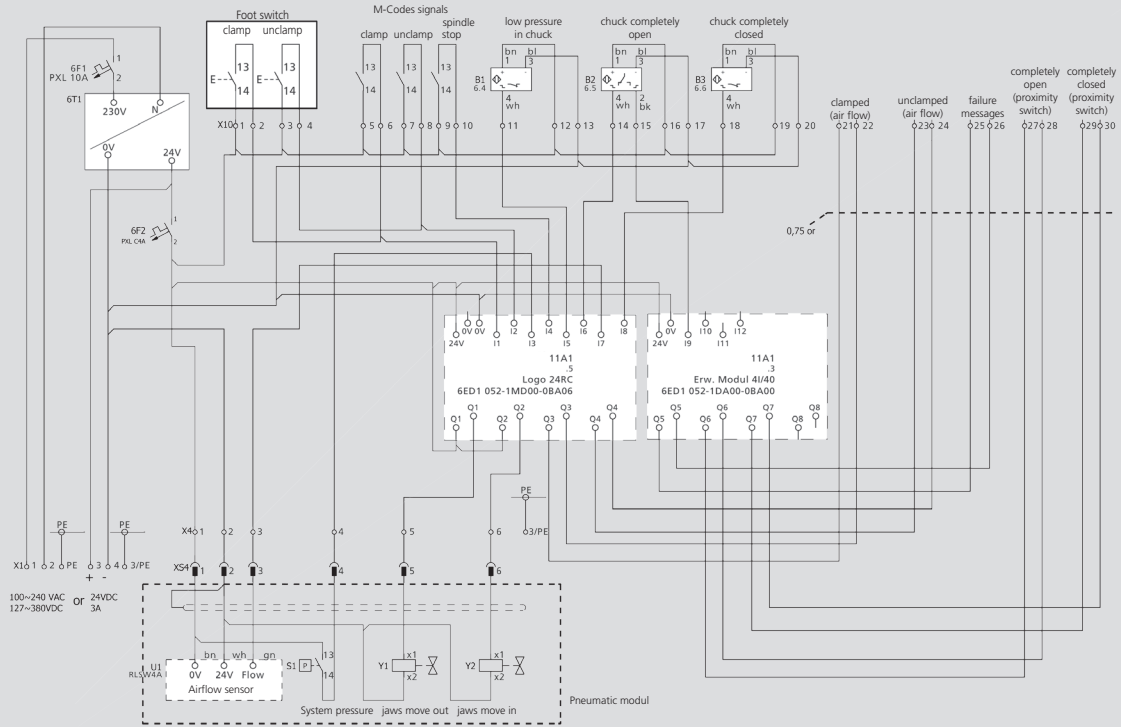

Electric diagram AC-XN

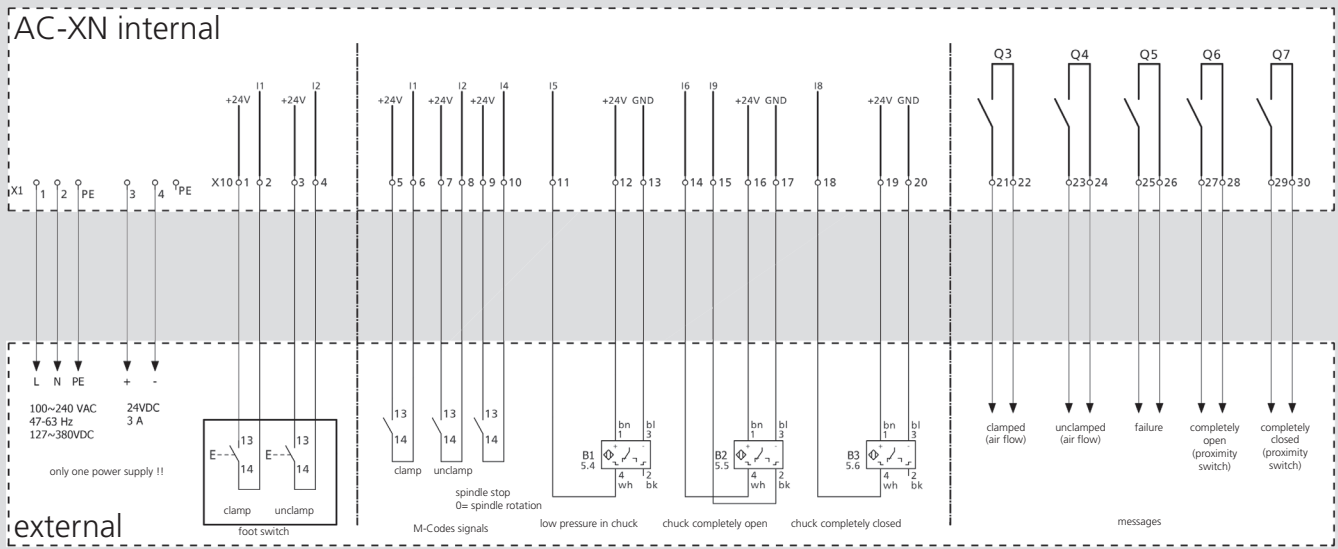

Pneumatic diagram AC-XN

