

# CUSTOMER BENEFITS

## SMW-AUTOBLOK is the inventor



SMW-AUTOBLOK - the inventor and pacemaker in technology for OCTG chucks. More than 40 years of experience ensure the highest productivity for all of our customers.

## Worldwide Service + Support



Our worldwide SMW-AUTOBLOK network guarantees immediate service, availability of parts and support wherever needed.

## Partner of oil industry



Working closely with our customers, we are able to provide new and innovative solutions as challenges arise.

## Widest range of OCTG products



SMW-AUTOBLOK offers a complete range of OCTG chucks as standard products. The need for expensive "special product" chucks with long lead times is eliminated.

## Fast time and high accuracy

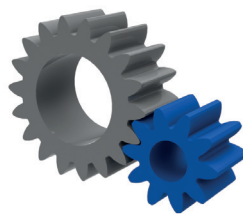

Improving production processes with rapid chuck actuation, SMW-AUTOBLOK's OCTG chucks increase productivity and decrease machine downtimes.



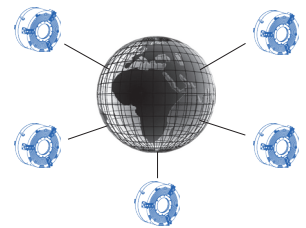







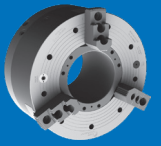

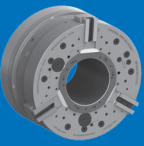

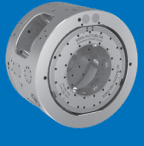
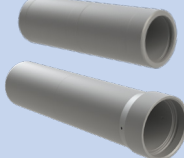



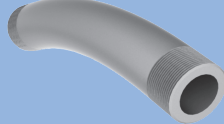

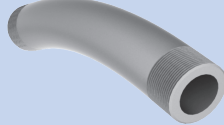

## Applications worldwide

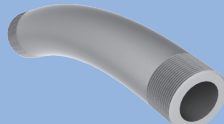

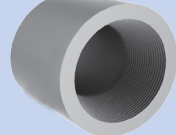
5 continents - 1 partner: All major players in the OCTG industry on 5 continents trust in SMW-AUTOBLOK as their reliable workholding partner.

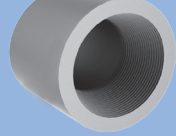
# Chuck finder for Oil Country Tubular Goods: Introduction

- Straight pipes
- Bent pipes
- Couplings

Chuck type						
Machining OCTG product	BB-N / BB-N-ES	BB-EXL2G	BB-SC	BB-AZ2G	BB-FZA2G	SF-RAZ2G
 <b>Straight pipes</b>	 Page 12 / 14	 Page 16	 Page 18	 Page 20		
 <b>Bent pipes with shimming</b>	 Page 12 / 14	 Page 16	 Page 18	 Page 20		
 <b>Bent pipes with external centering chuck</b>				 Page 20		
 <b>Bent pipes with integrated centering chuck</b>					 Page 24	
 <b>Threadings of couplings in 1 set-up</b>						 Page 30
 <b>Threadings of couplings in 2 set-ups</b>	 Page 12 / 14	 Page 16	 Page 18			 Page 30



**Ideal**



**Possible**

## Big Bore



Big Bore is synonymous for **self contained air chucks with large through holes**. Big Bore chucks allow for the full spindle bore of the machine to be utilized.

## Quick clamping circle



Optimal sized air feeds and valve systems guarantee a **quick clamping cycle**.

## ES

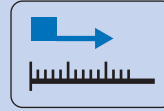

**ES** chucks offer **extended jaw stroke** for greater clearance to ensure safe loading and unloading of pipe.

## Spring clamp



**Spring clamp technology** ensures the quickest clamping cycles and the highest degree of safety under any conditions.

## Low maintenance



**Proofline** chucks are **fully sealed** and **low maintenance** allowing for long service intervals, minimizing machine downtime.

## AZ-2G

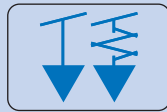

**AZ-2G** chucks offer the versatility of clamping either **compensating** or **self centering**.

## FZA-2G

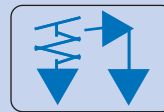

**FZA-2G** chucks **sequence 3 centering jaws** along with **3 compensating jaws** integrated within the same chuck body.

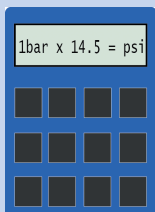

### Conversion table (US)

1 mm	=	0.03937 Inch	1 cm <sup>2</sup>	=	0.155 square inches
1 bar	=	14.5 psi	1 liter	=	1.05 quarts (qt)
1 kN	=	220.46 lbf	1 kg·m <sup>2</sup>	=	3417 lb square inches
1 kg	=	2.2046 lbs	1 liter / min	=	0.264 gallon / min

Data sheet						Performance characteristics		
OCTG chuck	Size	Outside dia. max	Work piece capacity	Time for a full clamping	Time for a full opening	Max. grip force (at max. pressure)	Height of chuck without adapter	Weight without jaws and adapter
	mm	mm	mm	max.	max.	kN	mm	kg
<b>BB-N</b> ▪ Big Bore ▪ Quick clamping circle	400 - 140	467	140	-	-	266	196	155
	470 - 191	470	191	4.5	3.0	191	196	160
	500 - 205	570	205	6.0	6.0	350	225	230
	500 - 230	570	230	6.0	6.0	316	225	200
	600 - 275	605	275	6.0	6.0	333	225	270
	630 - 310	685	310	6.5	6.5	366	263	420
	800 - 410	850	410	7.0	5.5	550	305	650
<b>BB-N-ES</b> ▪ Big Bore ▪ Quick clamping circle ▪ Extended stroke	400 - 140	467	140	on request	on request	216	240	200
	470 - 191	470	191	4.5	3.0	191	240	195
	500 - 205	570	205	6.0	4.5	316	280	340
	500 - 230	570	230	6.0	4.5	283	280	325
	600 - 275	605	275	6.0	4.5	308	280	350
	630 - 325	685	325	6.0	4.5	333	307.5	630
	850 - 375	850	375	7.0	5.5	333	354	970
	1000 - 560	1000	560	7.5	6.0	283	332	960
<b>BB-SC</b> ▪ Big Bore ▪ Spring clamp ▪ Low maintenance	600 - 275	750	275	3	3	150	320.5	516
	850 - 395	925	395	3	3	170	375.5	1025
	1020 - 565	1095	565	4.5	4.5	170	375.5	1256
<b>BB-AZ2G</b> ▪ Big Bore ▪ Self centering or compensating ▪ Extended stroke	685 - 275	685	275	on request	on request	266	380.5	800
	740 - 330	740	330	on request	on request	266	380.5	875
	800 - 390	800	800	on request	on request	300	380.5	1000
	1000 - 560	1000	560	on request	on request	300	380.5	1420
<b>BB-FZA2G</b> ▪ Big Bore ▪ Sequence chuck	740 - 275	740	275	on request	on request	149	516.5	1100
	800 - 330	800	330	on request	on request	133	516.5	1080
	920 - 390	920	390	on request	on request	255	546.5	1900
<b>SF-RAZ2G</b> ▪ Hydraulic indexing chuck ▪ Low maintenance	750	750	185	2	2	250	456	1018
	840	840	275	2	2	250	501	1286
	950	950	368	2	2	250	560	1650

Clamping times have been measured with the corresponding original SMW-AUTOBLOK air control unit on the SMW-AUTOBLOK test stand. For more information please contact SMW-AUTOBLOK.



# Overview Pipes

## Customer's OCTG product:

- Straight pipes
- Bent pipes

### CHUCK

### APPLICATION

### OCTG PRODUCT

### CUSTOMER BENEFITS

**BB-N**  
Page 12

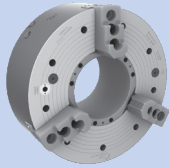

Threading of straight pipes with the original SMW Big Bore type BB-N.

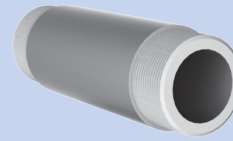

- **Quick jaw movement**  
more pipes per hour
- Can be used for other work pieces besides piping
- O.D. and I.D. clamping

**BB-N-ES**  
Page 14

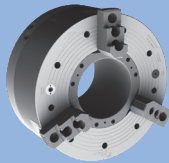

Threading of straight pipes with upset ends with the original SMW Big Bore type BB-N-ES.

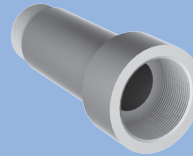

- **Quick jaw movement**  
more pipes per hour
- Large jaw stroke for easy loading of pipe and less danger of damaging threads when unloading

**BB-EXL2G**  
Page 16

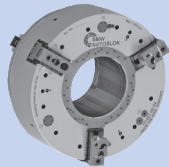

Threading of straight pipes with collars with the original SMW Big Bore Type BB-EXL2G.

**BB-SC**  
Page 18

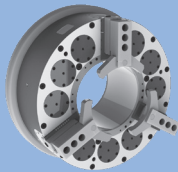

High production **spring clamp** chuck for threading of straight pipes with or without upset ends with the original SMW Big Bore type BB-SC.

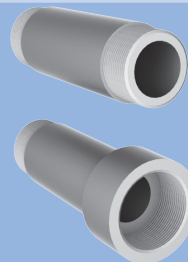

- **Full jaw stroke in 2 seconds** for highest productivity
- Fully sealed / low maintenance for highest availability of the machine
- Safe clamping of pipes even in longer machining processes with spring clamp technology

**BB-AZ2G**  
Page 20

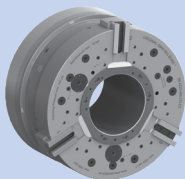

Threading of straight and bent pipes with the original SMW Big Bore type BB-AZ2G.

- **Self centering or compensating clamping** for universal use
- Quick jaw movement
- External centering device needed when used in compensating mode
- O.D. clamping only

**CC**  
Page 22

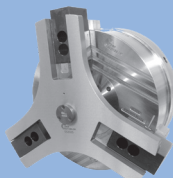

Threading of straight pipes with upset ends with the original SMW Big Bore type CC.

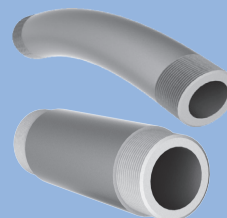

**BB-FZA2G**  
Page 24

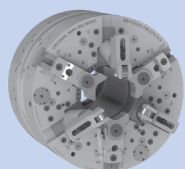

Threading of straight and bent pipes with integrated centering jaws with the original SMW Big Bore type BB-FZA2G.

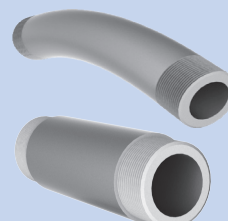

- **Integrated centering jaws for the pipe** = no external centering device needed
- Quick jaw movement
- Fully automatic programmable cycle

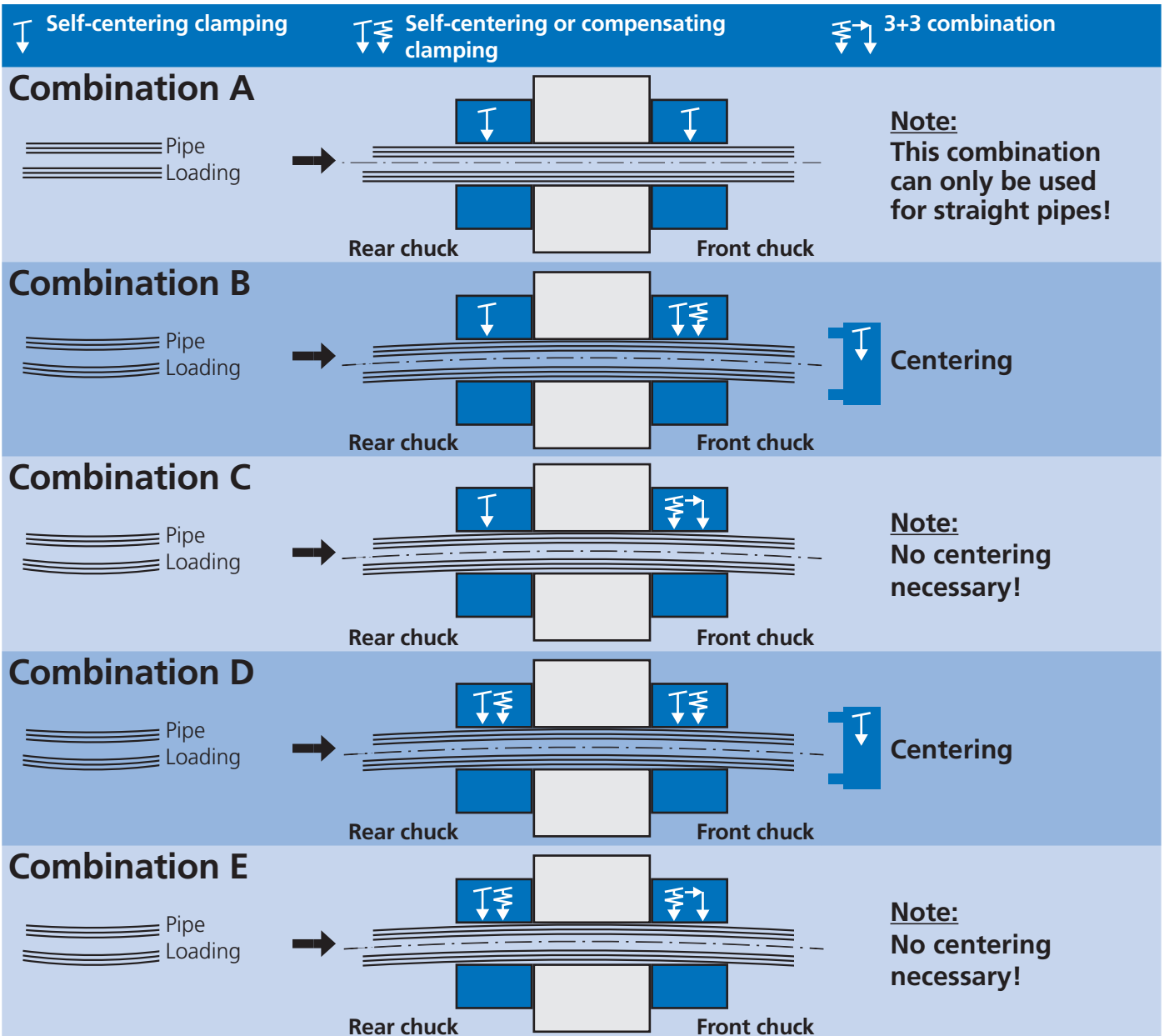

## Respective chuck matrix:

Self-centering clamping	Self-centering or compensating clamping	3 jaw + 3 jaw combination
 <p><b>BB-N / BB-N-ES</b> Page 12/14</p>  <p><b>BB-EXL2G</b> Page 16</p>	 <p><b>BB-AZ2G</b> Page 20</p>	 <p><b>BB-FZA2G</b> Page 24</p>
 <p><b>BB-SC</b> Page 18</p>		

## Centering options:

  <p><b>Chuck CC</b> Page 22</p>	<p><b>Turret</b> by customer</p>
--	--------------------------------------

# BIG BORE® BB-SC

Dentatura in POLLICI

## Autocentranti con cilindro incorporato con PASSAGGIO BARRA EXTRA GRANDE Ø 275 - 565 mm

- Ø mandrini 600 - 1020
- Serraggio tramite pacchi di molle
- Con corsa rapida e corsa di bloccaggio

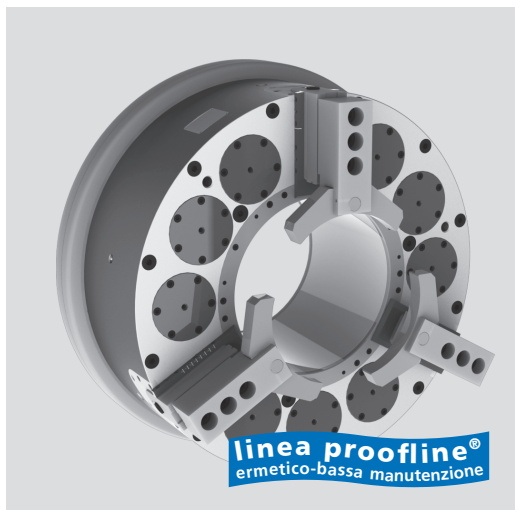

### Applicazioni

- Lavorazione delle estremità di tubi lunghi/serraggio autocentrante
- Corsa lunga delle griffe per bloccaggio di tubi con collarino
- Massima produttività grazie a tempi di apertura e chiusura < 3 sec.
- Lunghi intervalli di manutenzione = elevata disponibilità della macchina
- Lavorazione di tubi storti, regolati in centro con spessori manuali
- È possibile utilizzare il passaggio barra completo della macchina

### Caratteristiche tecniche

- Serraggio autocentrante tramite 9/6/3 pacchi di molle a scelta
- Pacchi di molle racchiuse in cartucce
- Apertura tramite cilindro pneumatico a singolo effetto incorporato
- Forza di serraggio costante grazie alla continua lubrificazione a grasso
- Comando a impulsi in apertura/chiusura per la regolazione della centratura del tubo
- Corsa lunga delle griffe suddivisa in CORSA RAPIDA E CORSA DI BLOCCAGGIO
- Ridotto consumo di aria
- Controllo corsa
- proffline® = mandrini ermetici - bassa manutenzione

### Dotazione standard

- Mandrino con viti di fissaggio
- 1 Serie di morsetti teneri
- 1 Serie di Tasselli a T con viti

### Esempio di ordine

Big Bore SC 850-395  
Cod. 053350

### Accessori

Unità di controllo AC-SC

## Il principio affidabile:

## Serraggio tramite pacchi di molle / apertura tramite cilindro pneumatico

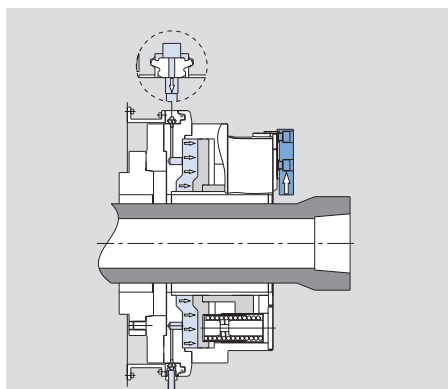

**Fig. 1**  
Apertura mandrino (solo con mandrino fermo). Le guarnizioni a profilo si deformano con la pressione dell'aria e aderiscono al corpo del mandrino, permettendo il riempimento del cilindro su un lato. Il pistone comprime i pacchi di molle e le griffe si aprono.

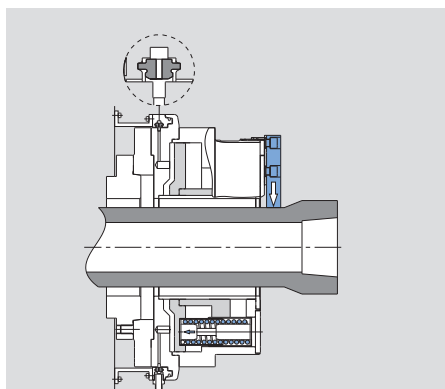

**Fig. 2**  
Serraggio mandrino (possibile anche con mandrino in rotazione). L'aria compressa viene disinserita. Le guarnizioni a profilo SMW tornano in posizione espansa e le molle trasmettono alle griffe la forza di bloccaggio.

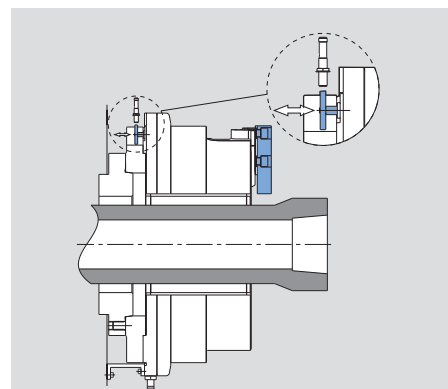

**Fig. 3**  
**Controllo della corsa**  
La corsa di bloccaggio delle griffe viene controllata meccanicamente. La misurazione di posizione/il controllo finale avvengono tramite sensore di prossimità.

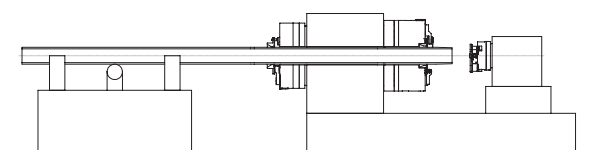

Lavorazione delle estremità di tubi con due mandrini per tornio.

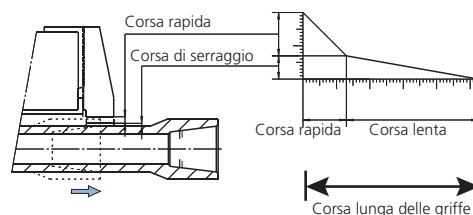

## Dati tecnici

Modello SMW-AUTOBLOK		BB-SC 600-275			BB-SC 850-395			BB-SC 1020-565		
Cod.		053540			053350			053570		
Passaggio barra	mm (poll.)	275 (10.83")			395 (15.55")			565 (22.24")		
Corsa totale per griffa	mm (poll.)	25.4 (1")			27 (1.06")			27 (1.06")		
Corsa rapida per griffa*	mm (poll.)	16.9 (0.67")			15 (0.59")			15 (0.59")		
Corsa di serraggio per griffa	mm (poll.)	8.5 (0.33")			12 (0.47")			12 (0.47")		
Pressione di apertura con 9 molle	bar (psi)	5 (73)			5 (73)			5 (73)		
Forza di serraggio max a 3/6/9 molle	kN (lbf)	50 (11240)	100 (22480)	150 (33721)	57 (12814)	113 (25403)	170 (38218)	57 (12814)	113 (25403)	170 (38218)
Velocità massima	giri/min.	1000			700			420		
Consumo d'aria per apertura a 5 bar (73 psi)	litri	60			115			139		
Massa (senza morsetti)	kg (lbs)	510 (1124)			930 (2050)			1260 (2779)		
Momento d'inerzia	kg·m <sup>2</sup>	34			101			223		

\* da NON utilizzare per il bloccaggio

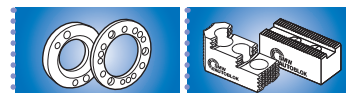

SMW-AUTOBLOK  
389

SMW-AUTOBLOK  
386

## Dimensioni e caratteristiche tecniche

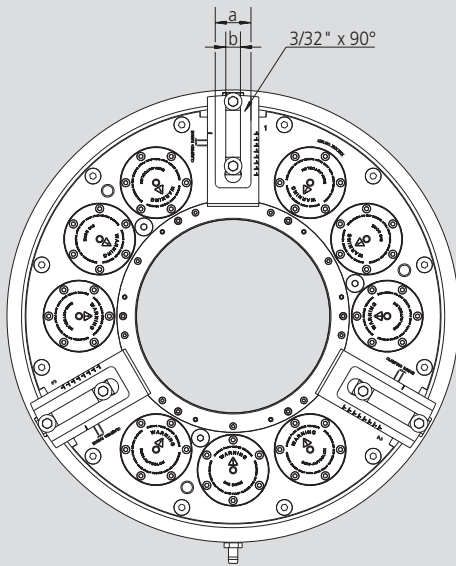

Pressione di apertura con tutte le molle montate  
min. 5 bar (73 psi), max. 8 bar (116 psi)

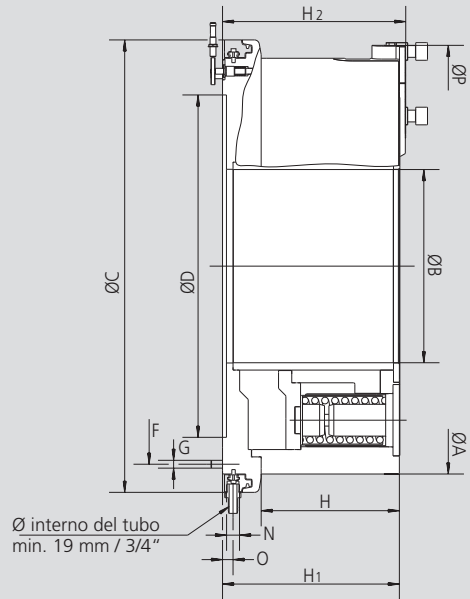
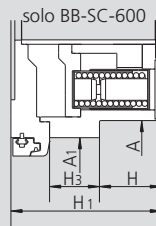

Con riserva di modifiche tecniche.  
Per maggiori informazioni contattare l'ufficio tecnico SMW-AUTOBLOK.

Modello SMW-AUTOBLOK			BB-SC 600-275	BB-SC 850-395	BB-SC 1020-565
<b>Attacco</b>			<b>Z520</b>	<b>Z700</b>	<b>Z870</b>
(BB-SC-600-275)	<b>A</b>	mm	605	850	1020
	<b>A1</b>	mm	675	-	-
Passaggio barra	<b>B</b>	mm	275	395	565
	<b>C</b>	mm	750	925	1095
	<b>D H6</b>	mm	520	700	870
	<b>F</b>	mm	640	810	980
	<b>G</b>		M12 (12x)	M16 (12x)	M16 (12x)
	<b>H</b>		126.7	282.5	282.5
	<b>H1</b>		307.5	361.5	361.5
	<b>H2</b>		320.5	374.5	374.5
(BB-SC-600-275)	<b>H3</b>		102	-	-
	<b>N</b>		G 3/4"	G 3/4"	G 3/4"
	<b>O</b>		21.5	21.5	21.5
Interferenza max.	<b>P</b>		655.8	902.8	1074
	<b>a</b>		58	73	73
	<b>b</b>		25.5	30	30
Corsa rapida		mm	16.9	15	15
Corsa di bloccaggio		mm	8.5	12	12
Corsa totale delle griffe		mm	25.4	27	27

## Flange di adattamento

Attacco  
ISO-A DIN 55026

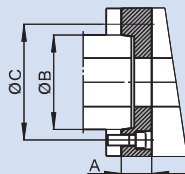

BB-SC	600-275			850-395		1020-565		
<b>Naso macchina</b>	A11	A15	A20	A15	A20	A15	A20	A28
Cod.	su richiesta	053590	053591	053362	053358	su richiesta	053595	053596

- Cycle clamp BB-N / BB-N ES
- Cycle clamp BB-SC

### Common parts for all Big Bore air circuits:

<b>V</b>	Non return valve towards the pneumatic system
<b>S</b>	Accumulator (approx. 90 normal liter / 23 gallon)
<b>W</b>	Air service unit 3/4" with filter, dryer, oiler and pressure regulator (0 - 10 bar), min. flowrate 3100 l/min (819 gallon / min); rec. Type: FRL 34S; Riegler & Co. KG, Bad Urach, Germany
<b>D</b>	Silencer 3/4", min. flowrate 15000 l / min (3963 gallon / min); rec. Type: 2311; Festo, Esslingen, Germany
<b>F</b>	Air flow sensor

Used connection parts for time measuring according to page 7:

- Length of hoses from air control to chuck: 3000 mm
- Inside dia. of hoses from air control to chuck 3/4" (19 mm)

### Cycle clamp BB-N / BB-N ES

action	Valve Y1	Valve Y2
clamp / unclamp	clamp	unclamp
1. chuck open		○
2. chuck clamp	○	

○ = Valve actuated for jaw movement

#### NOTE:

- All valves, hoses and fittings must be at least:
  - 1/2" inside dia. per function up to chuck size 600
  - 3/4" inside dia. per function on larger chuck sizes

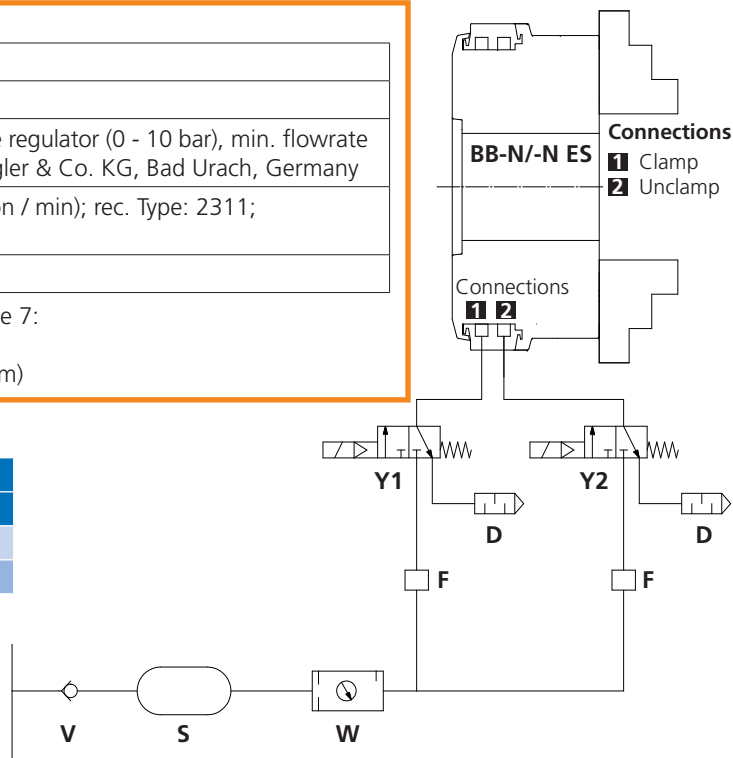

### Cycle standard clamp BB-SC

action	Valve Y1	Valve Y2
clamp / unclamp	unclamp	clamp
1. chuck open	X	
2. chuck clamp		○

### Cycle step mode / inching BB-SC

action	Valve Y1	Valve Y2
clamp / unclamp	unclamp	clamp
1. chuck open	X	
2. chuck clamp		○
3. step open	○	
4. step close		○

X = Valve permanently actuated

○ = Valve actuated for jaw movement

#### NOTE:

- All valves, hoses and fittings must be at least 3/4"

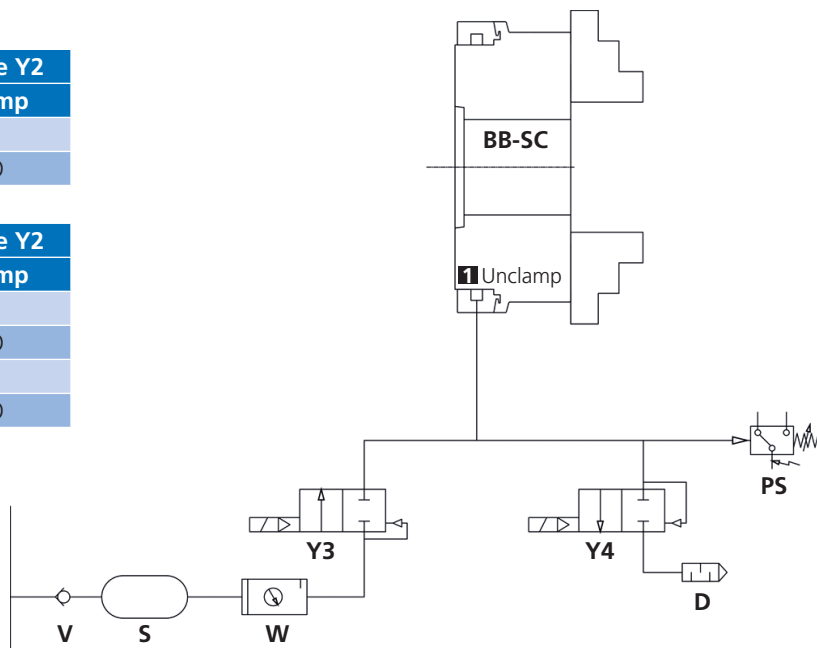

### Pneumatic connection parts for BB-N/-N ES and BB-SC:

<b>Y1/Y2</b>	3/2 solenoid valve 1", min. flowrate 3900 l / min (1031 gallon / min); rec. Type: NL6-SOV; Bosch Rexroth, Germany
<b>Y3/Y4</b>	2/2 solenoid valve 3/4", min. flowrate 3100 l / min (819 gallon / min); rec. Type: EGV 121/C78/3/4" BN; AVS Roemer GmbH, Koenigsdorf, Germany
<b>PS</b>	Pressure switch, 0 - 10 bar, 4 - 20 mA; rec. Type: A-10-6-BG410-HD1Z-AA-AGZ; WIKA, Klingenberg, Germany
<b>Q</b>	Quick exhaust valves, min. flowrate 6800 l / min (1765 gallon/min) rec. Type: 573, 1"; Bosch Rexroth, Germany