

CUSTOMER BENEFITS

SMW-AUTOBLOK is the inventor



SMW-AUTOBLOK - the inventor and pacemaker in technology for OCTG chucks. More than 40 years of experience ensure the highest productivity for all of our customers.

Worldwide Service + Support



Our worldwide SMW-AUTOBLOK network guarantees immediate service, availability of parts and support wherever needed.

Partner of oil industry



Working closely with our customers, we are able to provide new and innovative solutions as challenges arise.

Widest range of OCTG products



SMW-AUTOBLOK offers a complete range of OCTG chucks as standard products. The need for expensive "special product" chucks with long lead times is eliminated.

Fast time and high accuracy

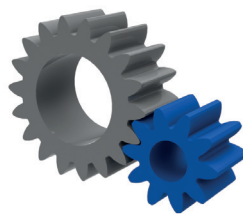

Improving production processes with rapid chuck actuation, SMW-AUTOBLOK's OCTG chucks increase productivity and decrease machine downtimes.



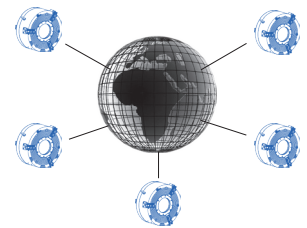







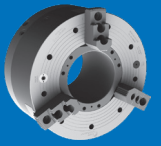

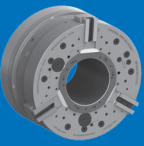

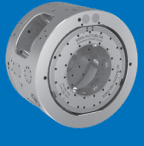
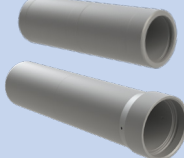



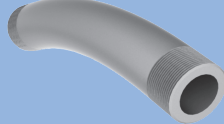

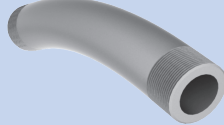

Applications worldwide

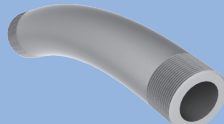

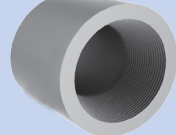
5 continents - 1 partner: All major players in the OCTG industry on 5 continents trust in SMW-AUTOBLOK as their reliable workholding partner.

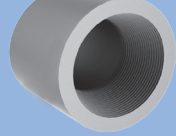
Chuck finder for Oil Country Tubular Goods: Introduction

- Straight pipes
- Bent pipes
- Couplings

Chuck type						
Machining OCTG product	BB-N / BB-N-ES	BB-EXL2G	BB-SC	BB-AZ2G	BB-FZA2G	SF-RAZ2G
 Straight pipes	 Page 12 / 14	 Page 16	 Page 18	 Page 20		
 Bent pipes with shimming	 Page 12 / 14	 Page 16	 Page 18	 Page 20		
 Bent pipes with external centering chuck				 Page 20		
 Bent pipes with integrated centering chuck					 Page 24	
 Threadings of couplings in 1 set-up						 Page 30
 Threadings of couplings in 2 set-ups	 Page 12 / 14	 Page 16	 Page 18			 Page 30



Ideal



Possible

Big Bore



Big Bore is synonymous for **self contained air chucks with large through holes**. Big Bore chucks allow for the full spindle bore of the machine to be utilized.

Quick clamping circle



Optimal sized air feeds and valve systems guarantee a **quick clamping cycle**.

ES

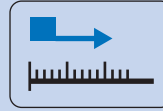

ES chucks offer **extended jaw stroke** for greater clearance to ensure safe loading and unloading of pipe.

Spring clamp



Spring clamp technology ensures the quickest clamping cycles and the highest degree of safety under any conditions.

Low maintenance



Proofline chucks are **fully sealed** and **low maintenance** allowing for long service intervals, minimizing machine downtime.

AZ-2G

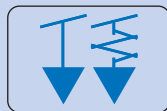

AZ-2G chucks offer the versatility of clamping either **compensating** or **self centering**.

FZA-2G

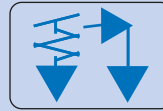

FZA-2G chucks **sequence 3 centering jaws** along with **3 compensating jaws** integrated within the same chuck body.

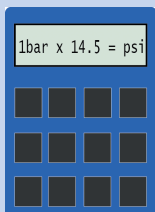

Conversion table (US)

1 mm	=	0.03937 Inch	1 cm ²	=	0.155 square inches
1 bar	=	14.5 psi	1 liter	=	1.05 quarts (qt)
1 kN	=	220.46 lbf	1 kg·m ²	=	3417 lb square inches
1 kg	=	2.2046 lbs	1 liter / min	=	0.264 gallon / min

Data sheet						Performance characteristics		
OCTG chuck	Size	Outside dia. max	Work piece capacity	Time for a full clamping	Time for a full opening	Max. grip force (at max. pressure)	Height of chuck without adapter	Weight without jaws and adapter
	mm	mm	mm	max.	max.	kN	mm	kg
BB-N ■ Big Bore ■ Quick clamping circle	400 - 140	467	140	-	-	266	196	155
	470 - 191	470	191	4.5	3.0	191	196	160
	500 - 205	570	205	6.0	6.0	350	225	230
	500 - 230	570	230	6.0	6.0	316	225	200
	600 - 275	605	275	6.0	6.0	333	225	270
	630 - 310	685	310	6.5	6.5	366	263	420
	800 - 410	850	410	7.0	5.5	550	305	650
BB-N-ES ■ Big Bore ■ Quick clamping circle ■ Extended stroke	400 - 140	467	140	on request	on request	216	240	200
	470 - 191	470	191	4.5	3.0	191	240	195
	500 - 205	570	205	6.0	4.5	316	280	340
	500 - 230	570	230	6.0	4.5	283	280	325
	600 - 275	605	275	6.0	4.5	308	280	350
	630 - 325	685	325	6.0	4.5	333	307.5	630
	850 - 375	850	375	7.0	5.5	333	354	970
	1000 - 560	1000	560	7.5	6.0	283	332	960
BB-SC ■ Big Bore ■ Spring clamp ■ Low maintenance	600 - 275	750	275	3	3	150	320.5	516
	850 - 395	925	395	3	3	170	375.5	1025
	1020 - 565	1095	565	4.5	4.5	170	375.5	1256
BB-AZ2G ■ Big Bore ■ Self centering or compensating ■ Extended stroke	685 - 275	685	275	on request	on request	266	380.5	800
	740 - 330	740	330	on request	on request	266	380.5	875
	800 - 390	800	800	on request	on request	300	380.5	1000
	1000 - 560	1000	560	on request	on request	300	380.5	1420
BB-FZA2G ■ Big Bore ■ Sequence chuck	740 - 275	740	275	on request	on request	149	516.5	1100
	800 - 330	800	330	on request	on request	133	516.5	1080
	920 - 390	920	390	on request	on request	255	546.5	1900
SF-RAZ2G ■ Hydraulic indexing chuck ■ Low maintenance	750	750	185	2	2	250	456	1018
	840	840	275	2	2	250	501	1286
	950	950	368	2	2	250	560	1650

Clamping times have been measured with the corresponding original SMW-AUTOBLOK air control unit on the SMW-AUTOBLOK test stand. For more information please contact SMW-AUTOBLOK.



Overview Pipes

Customer's OCTG product:

- Straight pipes
- Bent pipes

CHUCK

APPLICATION

OCTG PRODUCT

CUSTOMER BENEFITS

BB-N
Page 12

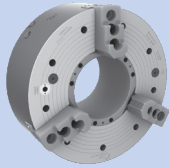

Threading of straight pipes with the original SMW Big Bore type BB-N.

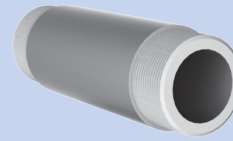

- **Quick jaw movement**
more pipes per hour
- Can be used for other work pieces besides piping
- O.D. and I.D. clamping

BB-N-ES
Page 14

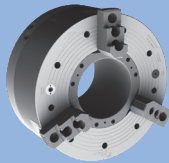

Threading of straight pipes with upset ends with the original SMW Big Bore type BB-N-ES.

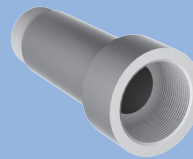

- **Quick jaw movement**
more pipes per hour
- Large jaw stroke for easy loading of pipe and less danger of damaging threads when unloading

BB-EXL2G
Page 16

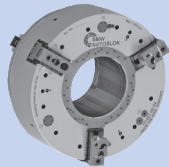

Threading of straight pipes with collars with the original SMW Big Bore Type BB-EXL2G.

BB-SC
Page 18

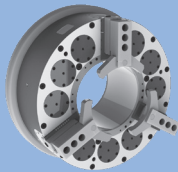

High production **spring clamp** chuck for threading of straight pipes with or without upset ends with the original SMW Big Bore type BB-SC.

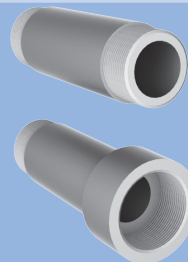

- **Full jaw stroke in 2 seconds** for highest productivity
- Fully sealed / low maintenance for highest availability of the machine
- Safe clamping of pipes even in longer machining processes with spring clamp technology

BB-AZ2G
Page 20

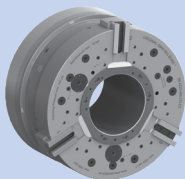

Threading of straight and bent pipes with the original SMW Big Bore type BB-AZ2G.

- **Self centering or compensating clamping** for universal use
- Quick jaw movement
- External centering device needed when used in compensating mode
- O.D. clamping only

CC
Page 22

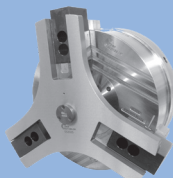

Threading of straight pipes with upset ends with the original SMW Big Bore type CC.

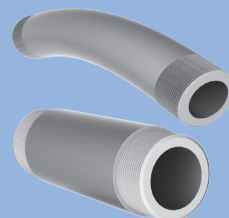

BB-FZA2G
Page 24

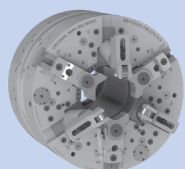

Threading of straight and bent pipes with integrated centering jaws with the original SMW Big Bore type BB-FZA2G.



- **Integrated centering jaws for the pipe** = no external centering device needed
- Quick jaw movement
- Fully automatic programmable cycle

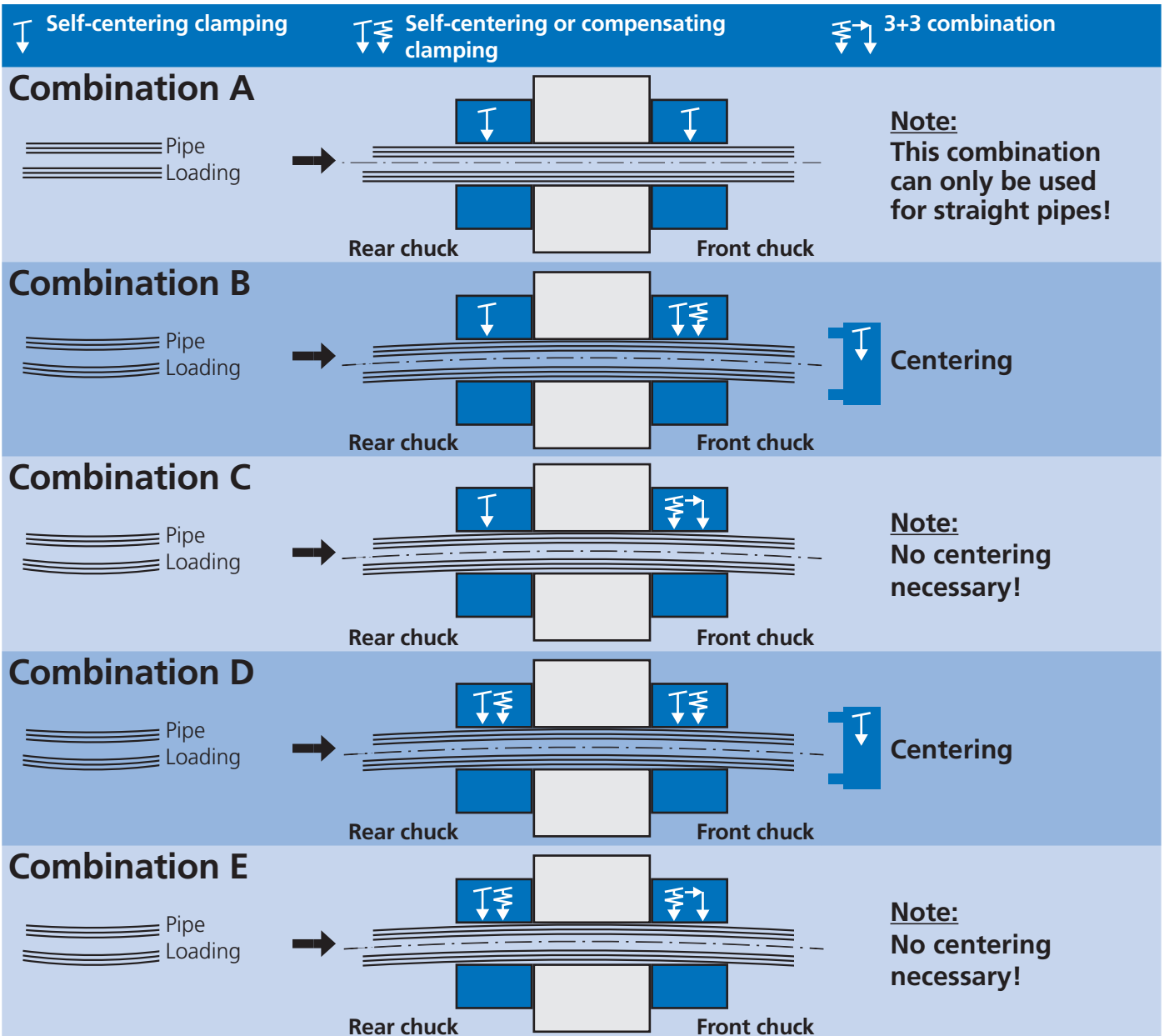

Respective chuck matrix:

Self-centering clamping	Self-centering or compensating clamping	3 jaw + 3 jaw combination
 <p>BB-N / BB-N-ES Page 12/14</p>  <p>BB-EXL2G Page 16</p>	 <p>BB-AZ2G Page 20</p>	 <p>BB-FZA2G Page 24</p>
 <p>BB-SC Page 18</p>		

Centering options:

  <p>Chuck CC Page 22</p>	<p>Turret by customer</p>
--	--------------------------------------

Lavorazione di tubi con i mandrini

BIG BORE 2G

BB-EXL2G

BB-AZ2G

BB-FZA2G

BIG BORE BB-N-EXL2G

- Autocentrante
- Corsa delle griffe EXTRA LUNGA
- Comando del movimento griffe passo a passo

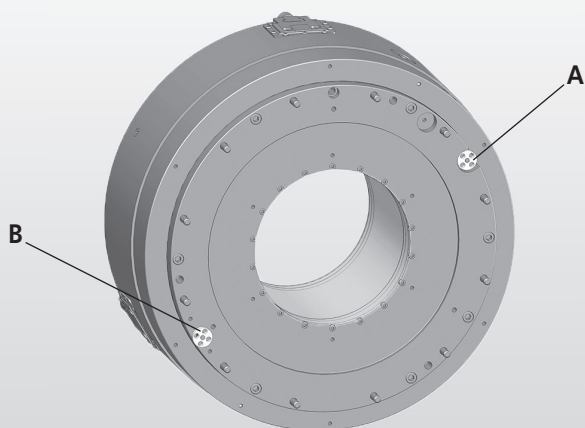

Dotazioni di sicurezza:

- A:** Controllo della pressione
- B:** Controllo della corsa

BIG BORE BB-AZ2G

- Autocentrante o compensante
- Corsa delle griffe EXTRA LUNGA

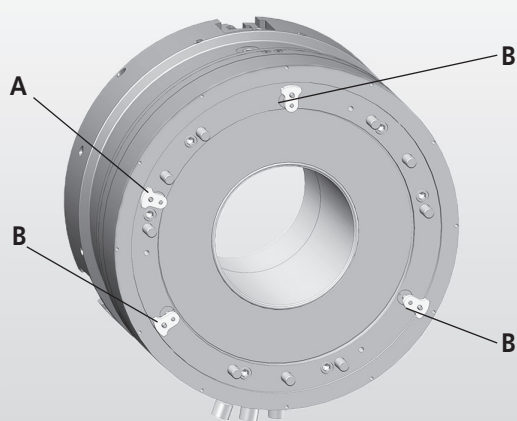

Dotazioni di sicurezza:

- A:** Controllo della pressione
- B:** Controllo corsa individuale per ciascuna griffa

BIG BORE BB-FZA2G

- mandrino a 6 griffe in sequenza (3 griffe di centraggio - 3 griffe compensanti)
- Corsa delle griffe EXTRA LUNGA (radiale e assiale)

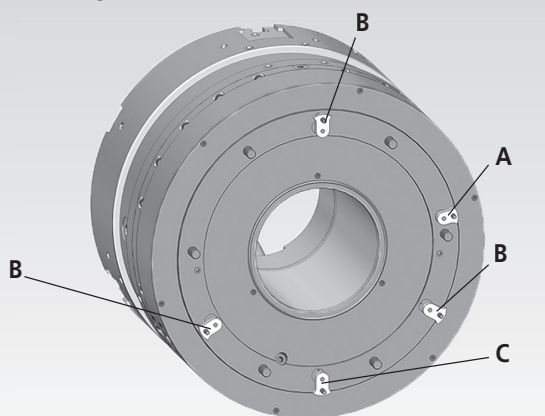

Dotazioni di sicurezza:

- A:** Controllo della pressione per griffe compensanti
- B:** Controllo corsa individuale per griffe compensanti
- C:** Controllo corsa per le griffe di centraggio retrattili

Tutti i mandrini 2G

- Corsa delle griffe EXTRA LUNGA
→ Grande spazio tra il tubo ed i morsetti

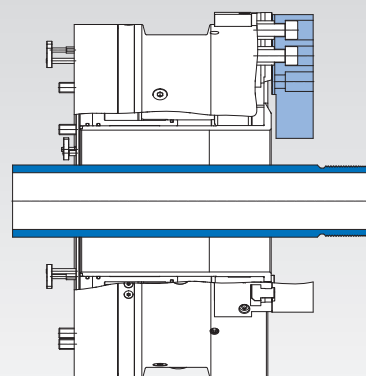

Corsa delle griffe EXTRA lunga per:

- Caricamento posteriore sicuro del tubo evitando urti con i morsetti
- Scaricamento posteriore sicuro del tubo evitando danni al filetto appena tornito

Vocabolario di serraggio

Corsa EXTRA lunga: la corsa del morsetto extra lunga avviene grazie al lungo movimento radiale delle griffe del mandrino BIG BORE 2G. Essa può essere una corsa completamente utilizzabile o una combinazione di una corsa rapida e corsa di serraggio. Una **corsa del morsetto EXTRA lunga** garantisce un sicuro caricamento e scaricamento del tubo.

Controllo corsa indipendente su ciascun morsetto: nella modalità di serraggio compensante, tutti e tre i morsetti dei mandrini BIG BORE 2G hanno un movimento radiale indipendente per compensare il disallineamento del tubo da lavorare. Il controllo corsa di ciascuna griffa è necessaria come unico modo per avere la sicurezza di escludere che una delle griffe sia arrivata a fine corsa prima di toccare il tubo.

Il controllo corsa su ciascun morsetto: assicura che tutti e 3 i morsetti sono nell'intervallo di corsa corretta e che il tubo verrà preso in modo preciso e sicuro. I segnali sono raccolti dai sensori di prossimità, e sono monitorati dall'unità di controllo pneumatica.

Controllo corsa delle griffe retrattili: sul mandrino BIG BORE FZA2G a 6 griffe sequenziali, i morsetti di centraggio sono usati solo a mandrino fermo per centrare i tubi nella zona di lavorazione. Il tubo è bloccato per la lavorazione solo con i morsetti di presa compensanti. Le griffe di centraggio sono quindi retratte per consentire la filettatura della zona precedentemente centrata. Per dare il segnale che i morsetti di centraggio sono stati retratti evitando interferenze con gli utensili, la posizione retratta dei morsetti di centraggio è monitorata da un sistema di controllo corsa per mezzo di sensori di prossimità.

Controllo della pressione: durante la lavorazione di un tubo, la pressione dell'aria che crea la forza di serraggio è mantenuta tramite una valvola di sicurezza. In caso di perdita di pressione, un sistema di controllo pressione manderà un segnale di allarme tramite un sensore di prossimità. Tutti i mandrini BIG BORE 2G hanno il controllo pressione come dotazione standard.

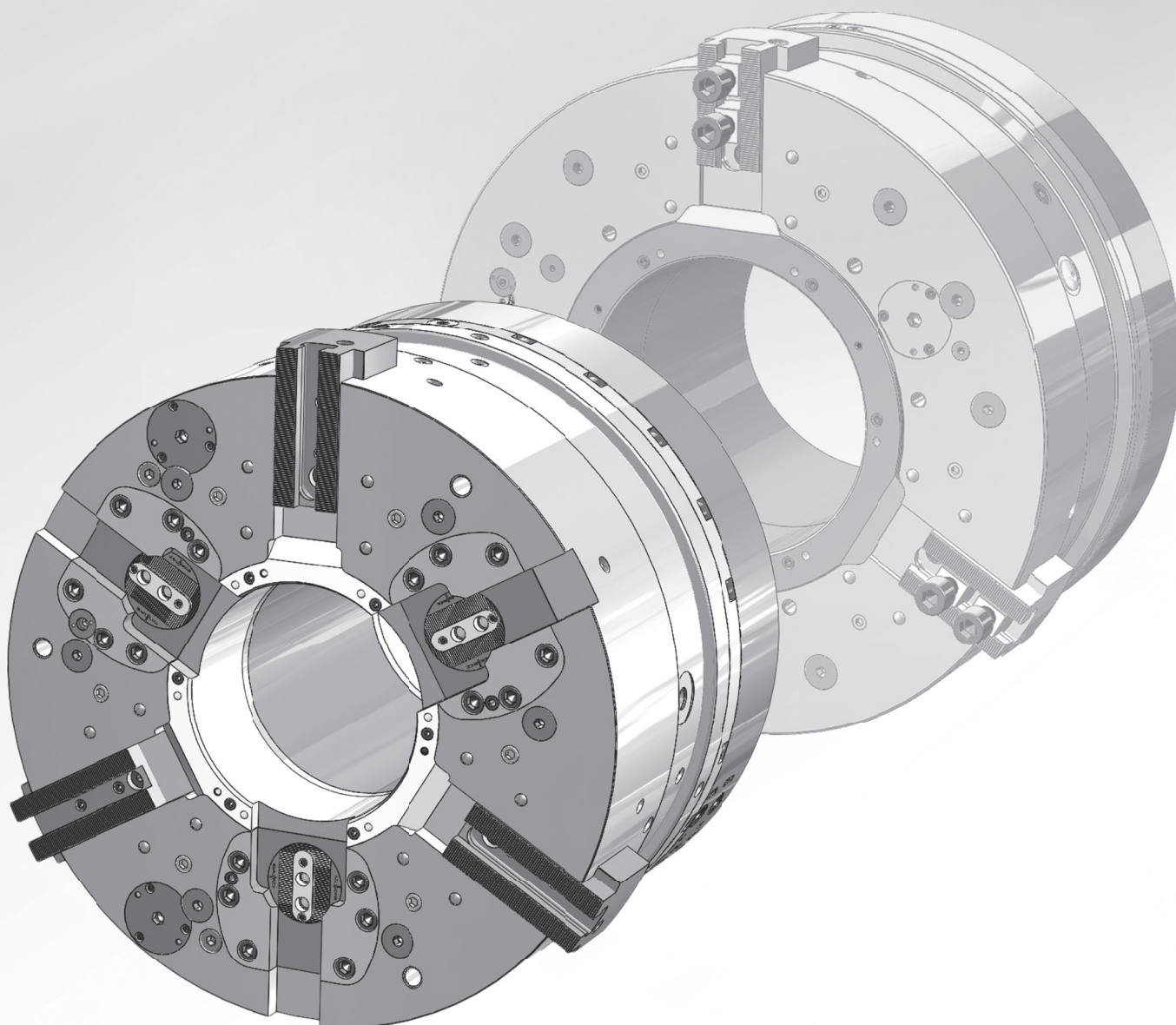

BIG BORE® BB-FZA2G

Dentatura in POLLICI

Autocentrante con cilindro pneumatico incorporato
a 6-griffe con bloccaggio sequenziale
PASSAGGIO BARRA EXTRA GRANDE Ø 275 - 390 mm

■ Ø mandrini 740 - 920

■ 3 griffe di centraggio retrattili e 3 griffe compensanti

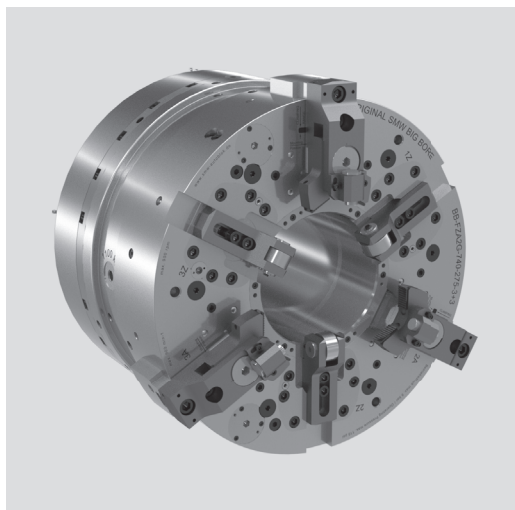

Applicazioni

- Corsa assiale e radiale EXTRA lunga delle griffe di centraggio
- Regolazione della posizione di centraggio assiale per la filettatura dei tubi
- Corsa rapida extra lunga e corsa di serraggio (in totale 1 1/2") dei morsetti compensanti
- Controllo corsa delle griffe di centraggio
- Controllo corsa di ciascuna griffa compensante
- Controllo della pressione

Caratteristiche tecniche

- 3+3 griffe pneumatiche: 3 di centraggio retrattili e 3 compensanti
- Nel bloccaggio, le griffe retrattili, avanzano e centrano il tubo esattamente nella zona che verrà filettata
- Solo per bloccaggio esterno
- La sequenza di bloccaggio è completamente automatica e programmabile
- Corsa delle griffe EXTRA LUNGA
- È possibile regolare la posizione assiale di centraggio modificando la posizione radiale dei morsetti di centraggio

Lavorazione di tubi storti con mandrino a griffe retrattili:

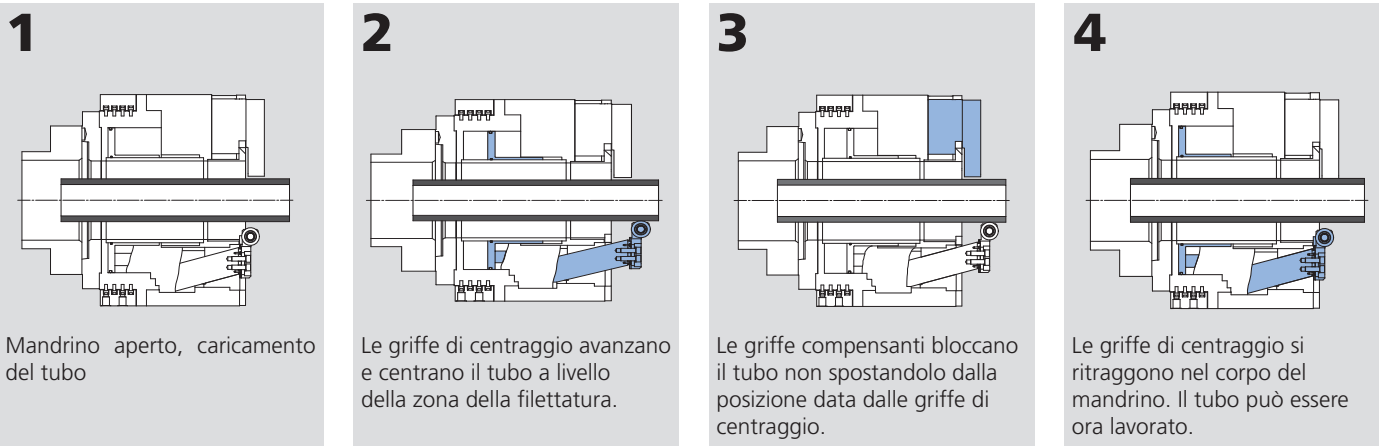

Regolazione della posizione assiale di centraggio

Cambiando la posizione radiale dei morsetti, la posizione di centraggio assiale può essere cambiata. La posizione di centraggio assiale è dipendente dalla regolazione radiale dei morsetti.

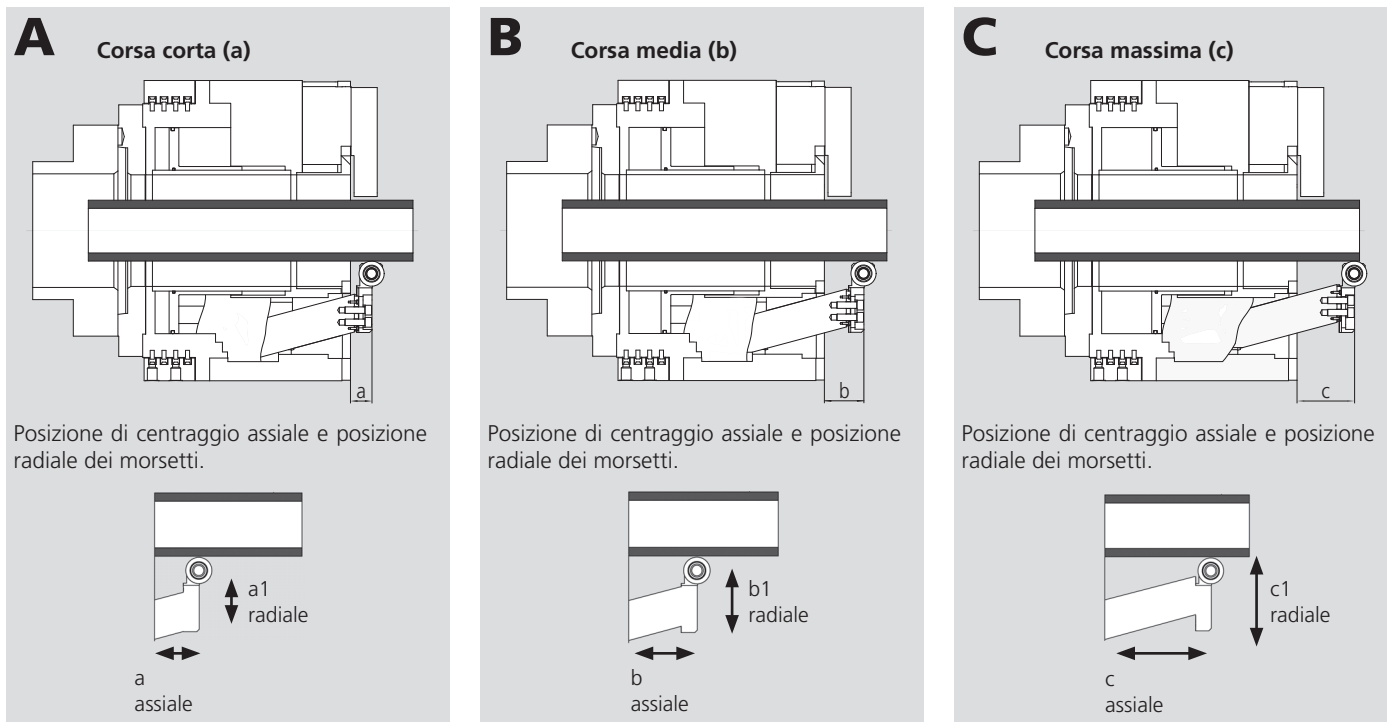

BIG BORE® BB-FZA2G

Dentatura in POLLICI

Dimensioni e caratteristiche tecniche

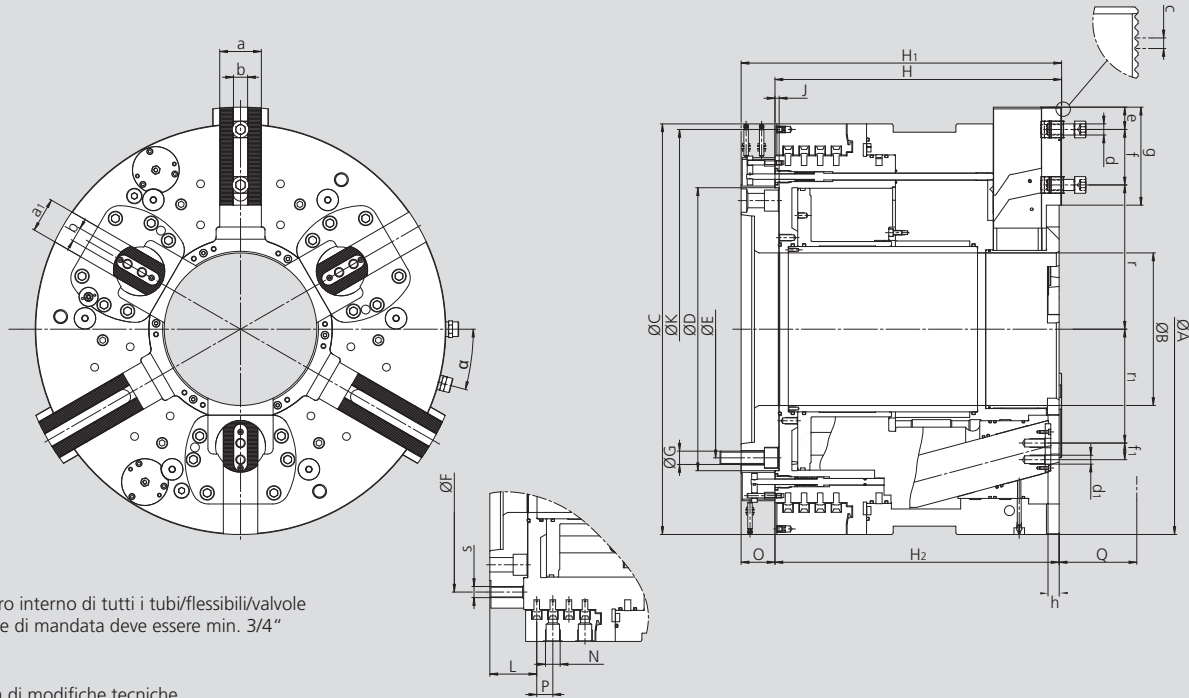

* Il diametro interno di tutti i tubi/flessibili/valvole delle linee di mandata deve essere min. 3/4"

Con riserva di modifiche tecniche.
Per maggiori informazioni contattare l'ufficio tecnico SMW-AUTOBLOK.

Modello SMW-AUTOBLOK			BB-FZA2G 740-275-A20	BB-FZA2G 800-330-A20	BB-FZA2G 920-390-A20
Cod.			054159	054300	054228
Diametro del mandrino	A	mm	740	800	920
Passaggio barra	B	mm	275	330	390
	C	mm	740	800	920
	D	mm	510	510	550
	E	mm	463.6	463.6	463,5
	F	mm	562	615	724
	G	mm	M24	M24	M24
	H	mm	516.5	516.5	546.5
Altezza mandrino	H1	mm	577.5	577.5	607.5
	H2	mm	512	512	542
	J	mm	7.5	7.5	7.5
	K	mm	720 / 6 x M8	780 / 6 x M8	890 / 6 x M8
	L	mm	84.5	84.5	86.5
Collegamento per tubi pneumatici	N	pollici	G 3/4"	G3/4"	G 3/4"
	O	mm	61	61	61
Corsa assiale delle griffe di centraggio	P	mm	3x29	3x29	3x31
	Q	mm	140	140	160
	a	mm	75	75	75
	a1	mm	62	62	62
	b	mm	25.5 H7	25.5 H7	25.5 H7
Viti di fissaggio morsetti	c	pollici	3/32" x 90°	3/32" x 90°	3/32" x 90°
Viti di fissaggio morsetti	d	mm	M20	M20	M20
min.	d1	mm	M16	M16	M16
	e	mm	30	30	30
max.	f	mm	100	100	135
	f1	mm	30	30	30
	g	mm	176.6	176.6	190
Dalla dentatura alla faccia del mandrino	h	mm	19	19	19
	r	mm	260	287.5	321
	r1	mm	205.2	232.7	270.3
	s	mm	M20	M20	M24
	α	ang.	15	15	15
Velocità max.		giri/min.	900	750	600
Forza di serraggio griffe autocompensanti a 6 bar		kN (lbf)	83 (18660)	83 (18660)	137 (30799)
Forza di serraggio griffe autocentranti a 6 bar		kN (lbf)	100 (22481)	114 (25628)	102 (22930)
Corsa per griffa (griffe autocompensanti)		mm (pollici)	38.1 (1 1/2")	38.1 (1 1/2")	38.1 (1 1/2")
corsa rapida		mm (pollici)	27.2 (1.07")	27.2 (1.07")	27.2 (1.07")
corsa di serraggio		mm (pollici)	10.9 (0.43")	10.9 (0.43")	10.9 (0.43")
Corsa per griffa (griffe autocentranti) max.		mm (pollici)	37.5 (1.48")	37.5 (1.48")	42.7 (1.68")
Consumo di aria per centraggio a 6 bar (87 psi) max.		litri	92	92	142
Consumo di aria per compensazione a 6 bar (87psi) max.		litri	30	30	54
Massa (senza morsetti)		kg (lbs)	1140 (2513)	1350 (2976)	1850 (4079)
Pressione di esercizio min./max.		bar (psi)	2 / 8 (29 / 116)	2 / 8 (29 / 116)	2 / 8 (29 / 116)
Momento d'inerzia		kg·m²	88	121	230

- Cycle clamp BB-AZ2G
- Cycle clamp BB-FZA2G

Cycle compensating clamp BB-AZ2G

action	Valve Y1	Valve Y2	Valve Y3
clamp / unclamp	clamp comp.	clamp self cent.	unclamp
1. chuck open		-	○
2. chuck compensating clamp	○	-	

Cycle self centering clamp BB-AZ2G

action	Valve Y1	Valve Y2	Valve Y3
clamp / unclamp	clamp comp.	clamp self cent.	unclamp
1. chuck open	-		○
2. chuck centering clamp	-	○	

○ = Valve actuated for jaw movement

NOTE:
All valves, hoses and fittings must be at least 3/4"

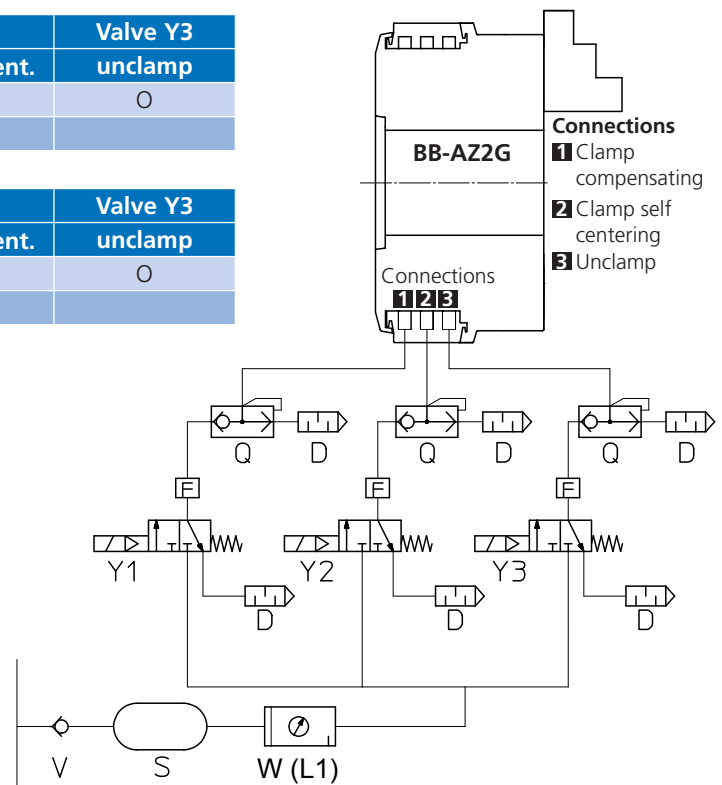

Cycle BB-FZA2G

action when pipe is loaded	Valve Y1	Valve Y2	Valve Y3	Valve Y4
	clamp cent.	unclamp cent.	clamp comp.	unclamp comp.
1. Self centering jaws forward and clamp	○			
2. Compensating jaws clamp			○	
3. Centering jaws open and retract		○		
4. Machining of pipe				
5. Compensating jaws open				○

○ = Valve actuated for jaw movement

NOTE:
All valves, hoses and fittings must be at least 3/4"

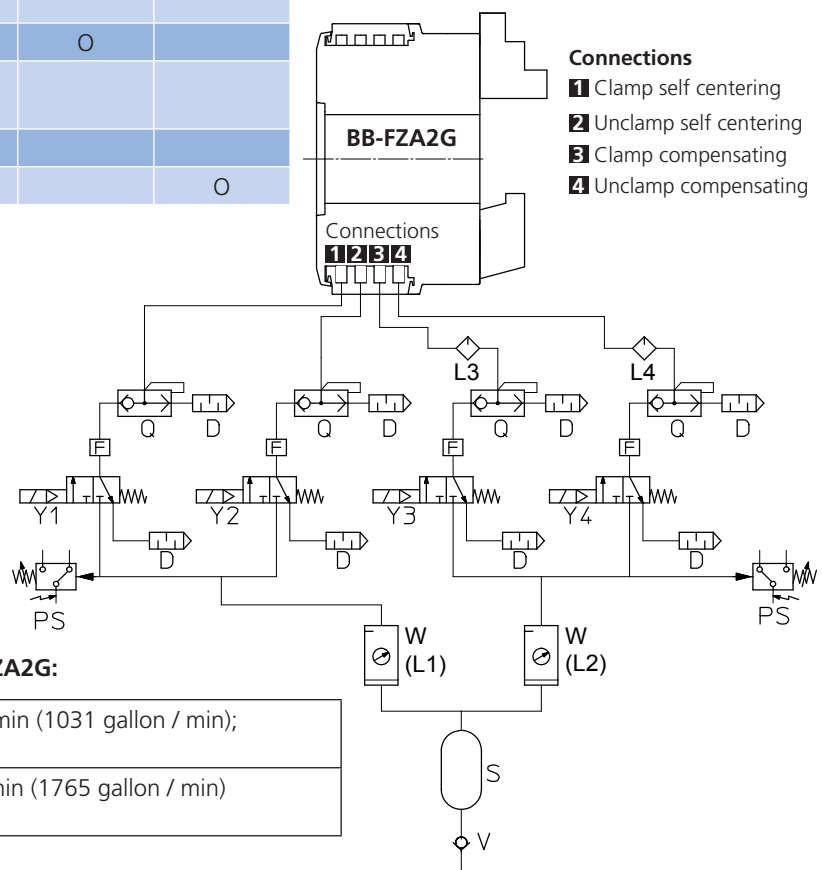

Pneumatic connection parts for BB-AZ2G and BB-FZA2G:

Y1/Y2/ Y3/Y4	3/2 solenoid valve 1", min. flowrate 3900 l / min (1031 gallon / min); rec. Type: NL6-SOV; Bosch Rexroth, Germany
Q	Quick exhaust valves, min. flowrate 6800 l / min (1765 gallon / min) rec. Type: 573, 1"; Bosch Rexroth, Germany