

CUSTOMER BENEFITS

SMW-AUTOBLOK is the inventor



SMW-AUTOBLOK - the inventor and pacemaker in technology for OCTG chucks. More than 40 years of experience ensure the highest productivity for all of our customers.

Worldwide Service + Support



Our worldwide SMW-AUTOBLOK network guarantees immediate service, availability of parts and support wherever needed.

Partner of oil industry



Working closely with our customers, we are able to provide new and innovative solutions as challenges arise.

Widest range of OCTG products



SMW-AUTOBLOK offers a complete range of OCTG chucks as standard products. The need for expensive "special product" chucks with long lead times is eliminated.

Fast time and high accuracy

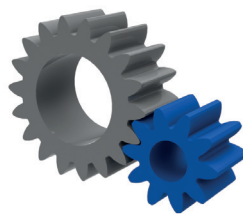

Improving production processes with rapid chuck actuation, SMW-AUTOBLOK's OCTG chucks increase productivity and decrease machine downtimes.



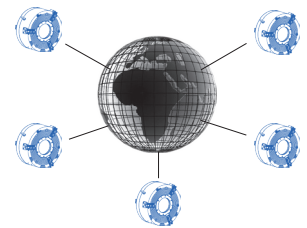







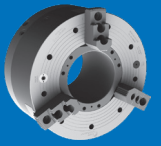

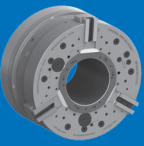

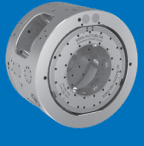
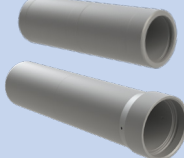



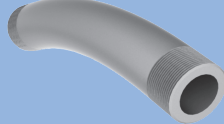

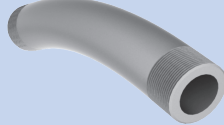

Applications worldwide

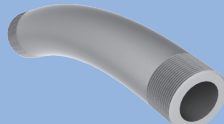

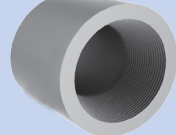
5 continents - 1 partner: All major players in the OCTG industry on 5 continents trust in SMW-AUTOBLOK as their reliable workholding partner.

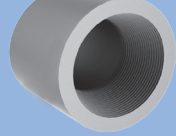
Chuck finder for Oil Country Tubular Goods: Introduction

- Straight pipes
- Bent pipes
- Couplings

Chuck type						
Machining OCTG product	BB-N / BB-N-ES	BB-EXL2G	BB-SC	BB-AZ2G	BB-FZA2G	SF-RAZ2G
 Straight pipes	 Page 12 / 14	 Page 16	 Page 18	 Page 20		
 Bent pipes with shimming	 Page 12 / 14	 Page 16	 Page 18	 Page 20		
 Bent pipes with external centering chuck				 Page 20		
 Bent pipes with integrated centering chuck					 Page 24	
 Threadings of couplings in 1 set-up						 Page 30
 Threadings of couplings in 2 set-ups	 Page 12 / 14	 Page 16	 Page 18			 Page 30



Ideal



Possible

Big Bore



Big Bore is synonymous for **self contained air chucks with large through holes**. Big Bore chucks allow for the full spindle bore of the machine to be utilized.

Quick clamping circle



Optimal sized air feeds and valve systems guarantee a **quick clamping cycle**.

ES

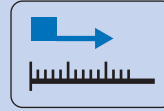

ES chucks offer **extended jaw stroke** for greater clearance to ensure safe loading and unloading of pipe.

Spring clamp



Spring clamp technology ensures the quickest clamping cycles and the highest degree of safety under any conditions.

Low maintenance



Proofline chucks are **fully sealed** and **low maintenance** allowing for long service intervals, minimizing machine downtime.

AZ-2G

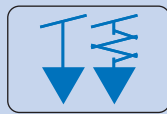

AZ-2G chucks offer the versatility of clamping either **compensating** or **self centering**.

FZA-2G

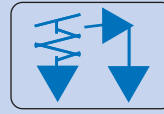

FZA-2G chucks **sequence 3 centering jaws** along with **3 compensating jaws** integrated within the same chuck body.

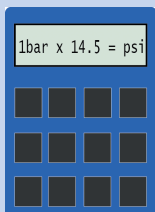

Conversion table (US)

1 mm	=	0.03937 Inch	1 cm ²	=	0.155 square inches
1 bar	=	14.5 psi	1 liter	=	1.05 quarts (qt)
1 kN	=	220.46 lbf	1 kg·m ²	=	3417 lb square inches
1 kg	=	2.2046 lbs	1 liter / min	=	0.264 gallon / min

Data sheet						Performance characteristics		
OCTG chuck	Size	Outside dia. max	Work piece capacity	Time for a full clamping	Time for a full opening	Max. grip force (at max. pressure)	Height of chuck without adapter	Weight without jaws and adapter
	mm	mm	mm	max.	max.	kN	mm	kg
BB-N ■ Big Bore ■ Quick clamping circle	400 - 140	467	140	-	-	266	196	155
	470 - 191	470	191	4.5	3.0	191	196	160
	500 - 205	570	205	6.0	6.0	350	225	230
	500 - 230	570	230	6.0	6.0	316	225	200
	600 - 275	605	275	6.0	6.0	333	225	270
	630 - 310	685	310	6.5	6.5	366	263	420
	800 - 410	850	410	7.0	5.5	550	305	650
BB-N-ES ■ Big Bore ■ Quick clamping circle ■ Extended stroke	400 - 140	467	140	on request	on request	216	240	200
	470 - 191	470	191	4.5	3.0	191	240	195
	500 - 205	570	205	6.0	4.5	316	280	340
	500 - 230	570	230	6.0	4.5	283	280	325
	600 - 275	605	275	6.0	4.5	308	280	350
	630 - 325	685	325	6.0	4.5	333	307.5	630
	850 - 375	850	375	7.0	5.5	333	354	970
	1000 - 560	1000	560	7.5	6.0	283	332	960
BB-SC ■ Big Bore ■ Spring clamp ■ Low maintenance	600 - 275	750	275	3	3	150	320.5	516
	850 - 395	925	395	3	3	170	375.5	1025
	1020 - 565	1095	565	4.5	4.5	170	375.5	1256
BB-AZ2G ■ Big Bore ■ Self centering or compensating ■ Extended stroke	685 - 275	685	275	on request	on request	266	380.5	800
	740 - 330	740	330	on request	on request	266	380.5	875
	800 - 390	800	800	on request	on request	300	380.5	1000
	1000 - 560	1000	560	on request	on request	300	380.5	1420
BB-FZA2G ■ Big Bore ■ Sequence chuck	740 - 275	740	275	on request	on request	149	516.5	1100
	800 - 330	800	330	on request	on request	133	516.5	1080
	920 - 390	920	390	on request	on request	255	546.5	1900
SF-RAZ2G ■ Hydraulic indexing chuck ■ Low maintenance	750	750	185	2	2	250	456	1018
	840	840	275	2	2	250	501	1286
	950	950	368	2	2	250	560	1650

Clamping times have been measured with the corresponding original SMW-AUTOBLOK air control unit on the SMW-AUTOBLOK test stand. For more information please contact SMW-AUTOBLOK.



BIG BORE® BB-N-ES

INCH SERRATION

Front-end pneumatic power chuck EXTRA large through-hole Ø 140 - 560 mm

- Chuck size 400 - 1000
- Extended jaw stroke
- 3 jaws

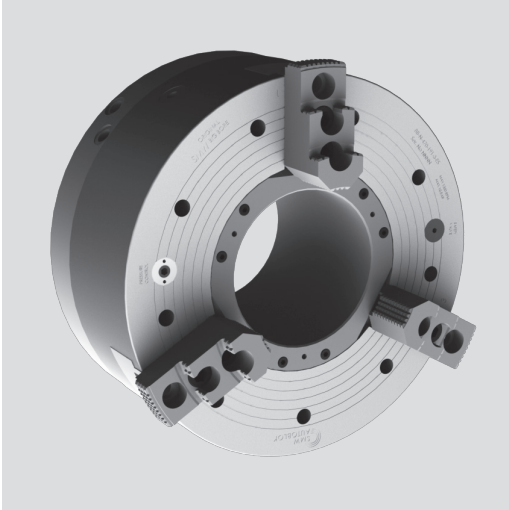

Application/customer benefits

- End machining of long pipes with upset ends
- Rapid and clamping stroke for short clamping cycles
- Full spindle bore can be used

Technical features

- Air chuck for external clamping with built-in pneumatic cylinder
- Rapid and clamping stroke
- Air feed via distributor ring and SMW-profile seals at stopped spindle
- Built-in non-return valves maintain the air pressure during machining
- Clamping pressure level constantly checked by a safety control system (only for external clamping)
- Clamping stroke control (no clamping in rapid stroke) is monitored

Standard equipment

- 3-jaw chuck
- 2 elbow unions G 1/2" (4 for BB-N-ES 1000)
- 12 mounting bolts (9 for the BB-N-ES 400)
- 1 lifting eye bolt
- 1 set T-nuts with bolts
- 1 set soft top jaws
- without distributor ring bracket

Ordering example

BIG BORE BB-N-ES 400 / Z310

Accessories

Control unit AC-BB / AC-XN
(see general catalog pages 378-381)

The principle invented by SMW: Air supply via distributor ring and SMW-profile seal rings

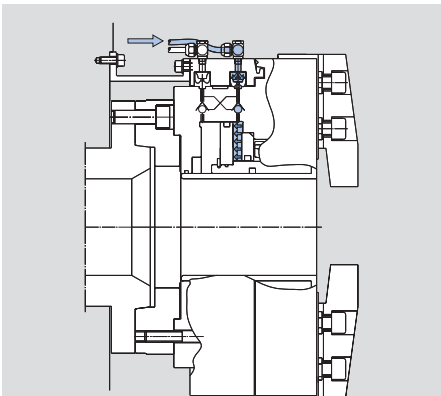

Picture 1

Open / close movement (only possible at stopped spindle). The profile seals deform radially under the pneumatic pressure, sealing on the chuck body and filling the cylinder chamber. When the clamping pressure is reached, the air feed is stopped, closing the twin non-return valve.

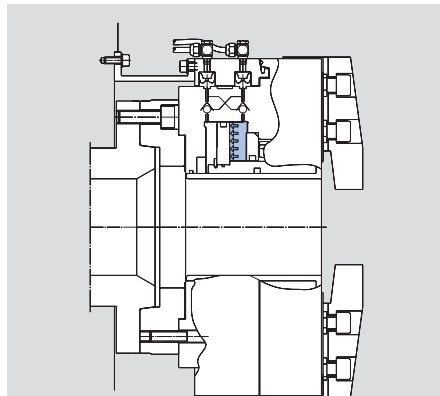

Picture 2

The SMW-profile seals lift to the expanded position, not touching the chuck body anymore. The clamping pressure is maintained by the twin non-return valve. The chuck can start to rotate.

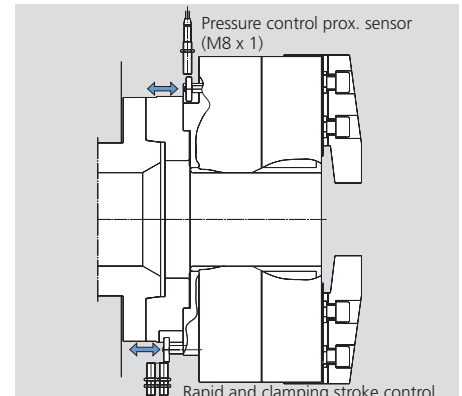

Picture 3

Safety pressure control: If the pressure is less than a pre-set safety level, the switch ring moves into the proximity switch field, sending an alarm signal.
Jaw stroke control: If the part is clamped in a not correct jaw stroke position, the switch ring moves into the proximity switch field sending an alarm signal.

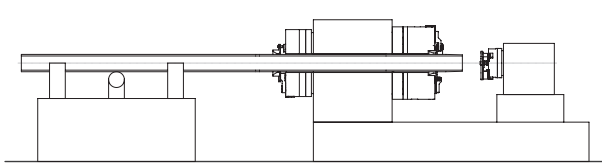

End machining of pipe with front and rear chucks

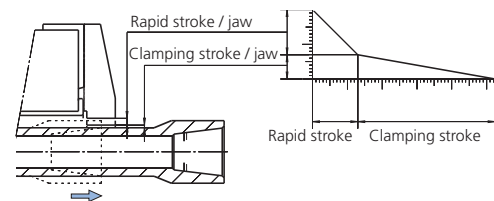

Technical data

SMW-AUTOBLOK Type BB-N-ES		400-140	470-191	500-205	500-230	600-275	630-325	850-375	1000-560
Id. No.		052330	053536	052651	052652	052990	052653	052654	052655
Through-hole	mm (inch)	140 (5.51")	191 (7.52")	205 (8.07")	230 (9.06")	275 (10.83")	325 (12.80")	375 (14.76")	560 (22.05")
Total stroke per jaw	mm (inch)	20 (0.79")	20 (0.79")	25.4 (1")	25.4 (1")	25.4 (1")	25.4 (1")	25.4 (1")	25.4 (1")
Rapid stroke per jaw*	mm (inch)	13 (0.51")	13 (0.51")	16.9 (0.67")	16.9 (0.67")	16.9 (0.67")	17.2 (0.67")	13.4 (0.53")	15 (0.59")
Clamping stroke per jaw	mm (inch)	7 (0.28")	7 (0.28")	8.5 (0.33")	8.5 (0.33")	8.5 (0.33")	8.2 (0.32")	12 (0.47")	10.4 (0.41")
Operating pressure min. / max.	bar (psi)	2 / 10 (29 / 145)							
Piston area	cm ²	705	565	1004	895	954	1192	1340	1090
Gripping force at 6 bar	kN (lbf)	130 (29225)	115 (25853)	190 (42714)	170 (38218)	185 (41590)	200 (44962)	200 (44962)	170 (38218)
Max. speed	r.p.m.	1300	1300	1100	1300	1100	900	750	450
Air consumption / jaw stroke at 6 bar	liter	29	22	41	37	39	48	79	57
Weight (without top jaws)	kg (lbs)	200 (441)	190 (419)	340 (750)	325 (717)	360 (794)	630 (1389)	970 (2138)	960 (2116)
Moment of inertia	kg·m ²	6.5	9.83	16.4	16.1	19	36	105	160

* May not be used for clamping.



SMW-AUTOBLOK
367

SMW-AUTOBLOK
366

BIG BORE® BB-N-ES

INCH SERRATION

■ Main dimensions and technical data

Jaw position: Open for external clamping

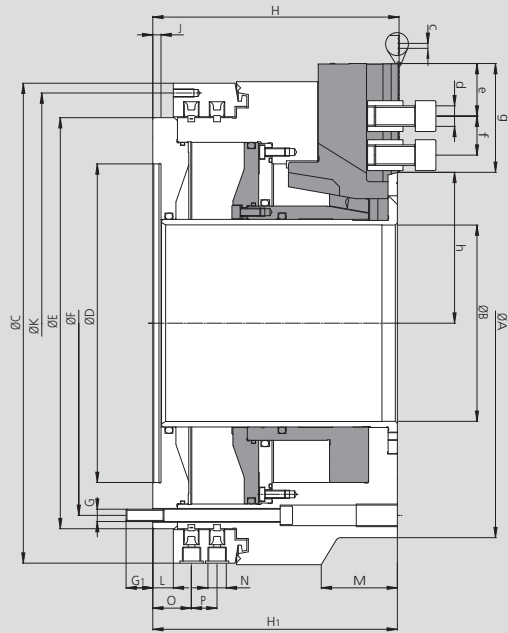
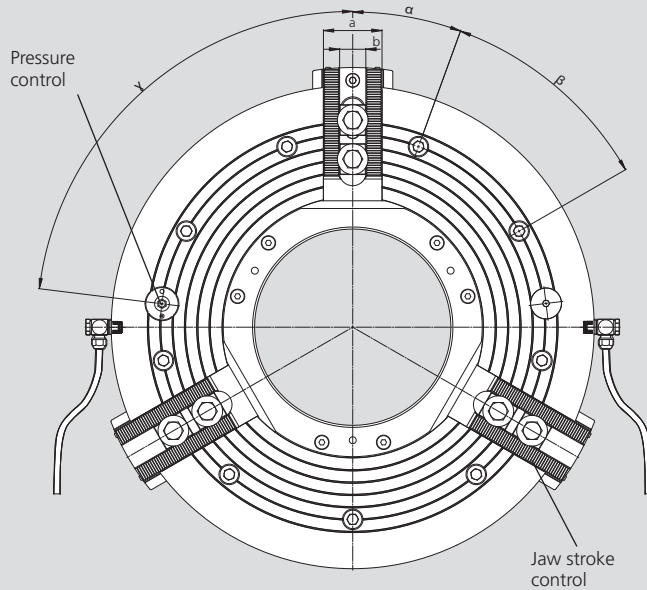

* All hoses / piping must be at least 1/2" ID and min 3/4" ID from chuck size 630 on.

BB-N-ES 1000 needs 2 hoses per function open / close (see installation manual).

To determine the exact position of the jaw stroke control and the pressure control please ask for a customer drawing.

Subject to technical changes.

For more detailed information please ask our customer service.

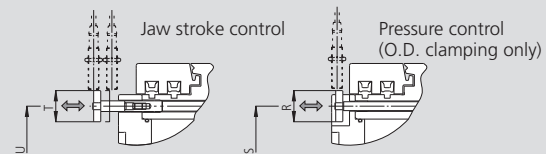

enlarged illustration

SMW-AUTOBLOK Type BB-N-ES			400-140	470-191	500-205	500-230	600-275	630-325	850-375	1000-560
Id. No.			052330	053536	052651	052652	052990	052653	052654	052655
Mounting			Z310	Z310	Z415	Z415	Z450	Z510	Z700	Z700
	A	mm	467	470	570	570	605	685	850	1000
	B	mm	140	191	205	230	275	325	375	560
	C	mm	467	467	570	570	605	685	850	925
	D H6	mm	310	310	415	415	450	510	700	700
	E	mm	400	400	500	500	535	610	775	850
Fixing bolts circle	F	mm	374	374	474	474	508	580	745	815
	G	mm	M12	M12	M12	M12	M12	M16	M16	M16
	G1	mm	26	26	25	25	25	30	30	30
	H	mm	240	240	282	282	282	307.5	354	332
	H1	mm	238	238	280	280	280	305.5	352	330
	J	mm	8	8	8	8	8	8	8	10
Thread circle 6 x M8	K	mm	448	448	550	550	585	666	830	910
	L	mm	20	20	20	20	20	20	25	33
	M	mm	-	-	-	-	-	-	-	224
Pneumatic connection	N	inch	G 1/2"	G 1/2"	G 1/2"	G 1/2"	G 1/2"	G 1/2"	G 1/2"	G 1/2"
	O	mm	37	37	37	37	37	39.5	44.5	52.5
	P	mm	26	26	26	26	26	33	33	33
	R	mm	35	35	35	35	35	42	35	42
	S	mm	374	374	474	474	508	580	745	815
	T	mm	35	35	35	35	35	35	35	35
	U	mm	374	374	474	474	508	580	745	815
	a	mm	57	57	57	57	57	75	75	75
	b	mm	25.5	25.5	25.5	25.5	25.5	30	30	30
Serration	c	inch	3/32" x 90°	3/32" x 90°	3/32" x 90°	3/32" x 90°	3/32" x 90°	3/32" x 90°	3/32" x 90°	3/32" x 90°
Bolt ISO 4762 12.9	d	mm	M20	M20	M20	M20	M20	M24	M24	M24
Min.	e	mm	14	14	14	14	14	16	16	16
T-nuts distance min. / max.	f	mm	38 / 90	38 / 85	38 / 104	38 / 92	38 / 79	47 / 100	47 / 140	47 / 125
Serration length	g	mm	121	106	140	127.5	116.5	138	182	166
Min. / max.	h	mm	104 / 124	127 / 147	145.6 / 171	158 / 182.5	179.1 / 204.5	204.6 / 230	242.6 / 268	334.6 / 360
	α	deg.	20	20	15	15	15	15	15	15
	β	deg.	9 x 40	9 x 40	12 x 30	12 x 30	12 x 30	12 x 30	12 x 30	12 x 30
(Pressure control)	γ	deg.	83	83	60	60	60	60	60	60

BIG BORE® BB-N-ES

INCH SERRATION

■ Top jaws

MHB-D Hard reversible top jaws

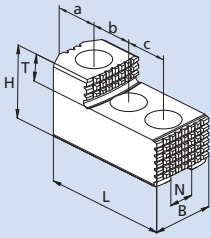

Gripping ranges

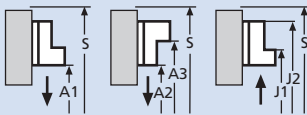

Chuck BB-N-ES	400-140	470-191	500-205	500-230	600-275	630-325	850-375	1000-560
Jaw type	MHB-D 500	MHB-D 500	MHB-D 500	MHB-D 500	MHB-D 500	MHB-D 630	MHB-D 800	MHB-D 800
Id. No.	12084546	12084546	12084546	12084546	12084546	12086446	12088046	12088046
B	60	60	60	60	60	75	75	75
H	75	75	75	75	75	85	85	85
L	140	140	140	140	140	160	220	220
T	2 x 19	2 x 19	2 x 19	2 x 19	2 x 19	30	30	30
N	25.5	25.5	25.5	25.5	25.5	30	30	30
Serration	3/32" x 90°	3/32" x 90°	3/32" x 90°	3/32" x 90°	3/32" x 90°	3/32" x 90°	3/32" x 90°	3/32" x 90°
a	46	46	46	46	46	30	51	51
b	38	38	38	38	38	50	62	62
c	38	38	38	38	38	50	62	62
kg / set	6.6	6.6	6.6	6.6	6.6	13.5	19.5	19.5
A1	78-264	113-270	175-388	200-388	252-422	295-500	320-610	470-760
A2	125-310	160-315	225-435	250-435	376-546	295-500	330-620	480-770
A3	310-495	345-500	410-620	435-620	475-645	495-700	590-865	745-1030
J1	-	-	-	-	-	-	-	-
J2	-	-	-	-	-	-	-	-
S	635	640	765	765	765	870	1070	1250

GAB Hard top jaws

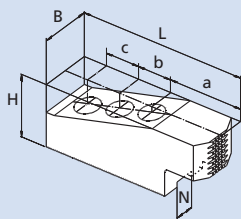

Gripping ranges

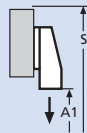

Chuck BB-N-ES	400-140	470-191	500-205	500-230	600-275	630-325	850-375	1000-560
Jaw type	GAB 500	GAB 500	GAB 500	GAB 500	GAB 500	GAB 630	GAB 800	GAB 800
Id. No.	12085146	12085146	12085146	12085146	12085146	12086546	12089046	12089046
B	55	55	55	55	55	75	75	75
H	73	73	73	73	73	82	82	82
L	195	195	195	195	195	245	320	320
N	25.5	25.5	25.5	25.5	25.5	30	30	30
Serration	3/32" x 90°	3/32" x 90°	3/32" x 90°	3/32" x 90°	3/32" x 90°	3/32" x 90°	3/32" x 90°	3/32" x 90°
a	96	96	96	96	96	113	165	165
b	38	38	38	38	38	50	60	60
c	38	38	38	38	38	50	60	60
kg / set	16.5	16.5	16.5	16.5	16.5	31.5	40.5	40.5
A1	25-160	60-165	75-290	100-290	135-306	130-335	95-385	245-535
S	635	640	765	765	740	870	1060	1210

WBSA-D / WBC-D Soft top jaws

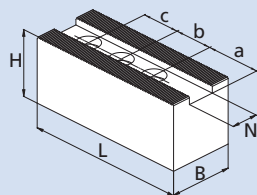

Gripping ranges

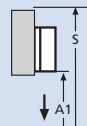

Chuck BB-N-ES	400-140	470-191	500-205	500-230	600-275	630-325	850-375	1000-560
Jaw type	WBSA-D 500	WBSA-D 500	WBSA-D 500	WBSA-D 500	WBSA-D 500	WBC-D 630	WBC 800	WBC-D 800
Id. No. (pc.)	12075050	12075050	12075050	12075050	12075050	12076440	12078040	12078040
B	60	60	60	60	60	80	80	80
H	60	60	60	60	60	80	80	80
L	170	170	170	170	170	240	320	320
N	25.5	25.5	25.5	25.5	25.5	30	30	30
Serration	3/32" x 90°	3/32" x 90°	3/32" x 90°	3/32" x 90°	3/32" x 90°	3/32" x 90°	3/32" x 90°	3/32" x 90°
a	69	69	69	69	69	110	165	165
b	38	38	38	38	38	50	60	60
c	38	38	38	38	38	50	60	60
kg / piece	3.6	3.6	3.6	3.6	3.6	11	15	15
A1	35-220	70-225	130-335	155-335	189-360	135-340	95-385	245-535
S	590	595	720	720	740	865	1060	1210



JAWS-CATALOG

Request or download:
www.smw-autoblok.de

BIG BORE® BB-N-ES

INCH SERRATION

- Top jaws
- T-nuts
- Spindle adapters

WBC-D, WBCL-D Soft top jaws long version

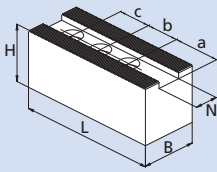

Gripping ranges

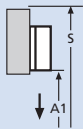

Chuck BB-N-ES	400-140	470-191	500-205	500-230	600-275	630-325	850-375	1000-560
Jaw type	WBC-D 502	WBC-D 502	WBC-D 502	WBC-D 502	WBC-D 502	WBC-D 800	WBCL-D 800	WBCL-D 800
Id. No. (pc.)	12075140	12075140	12075140	12075140	12075140	12078040	12079040	12079040
B	60	60	60	60	60	80	80	80
H	60	60	60	60	60	80	80	80
L	205	205	205	205	205	320	390	390
N	25.5	25.5	25.5	25.5	25.5	30	30	30
Serration	3/32" x 90°	3/32" x 90°	3/32" x 90°	3/32" x 90°	3/32" x 90°	3/32" x 90°	3/32" x 90°	3/32" x 90°
a	104	104	104	104	104	165	230	230
b	38	38	38	38	38	60	60	60
c	38	38	38	38	38	60	60	60
kg	4.5	4.5	4.5	4.5	4.5	15	18	18
A1	-	0-150	60-275	85-275	119-290	25-210	25-255	115-405
S	-	595	720	720	740	895	1070	1220

NST T-nuts

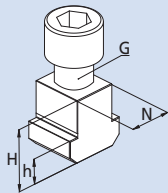

Chuck BB-N-ES	400-140	470-191	500-205	500-230	600-275	630-325	850-375	1000-560
T-nut type	NST	NST	NST	NST	NST	NST	NST	NST
Id. No. (pc.)	12065020	12065020	12065020	12065020	12065020	13063900	13063900	13063900
N	25.5	25.5	25.5	25.5	25.5	30	30	30
H	34	34	34	34	34	44	44	44
h	15	15	15	15	15	18	18	18
G	M 20	M 20	M 20	M 20	M 20	M 24	M24	M 24
Bolt ISO 4762 12.9	M20 x 40	M20 x 40	M20 x 40	M20 x 40	M20 x 40	M24 x 60	M24 x 60	M24 x 60

Spindle adapters for BIG BORE chucks

ISO-A DIN 55026 Spindle adapters

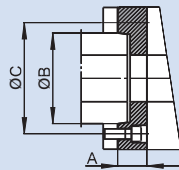

BB-N-ES	400-140/470-191			500-205/500-230			600-275			630-325			850-375		1000-560	
Spindle nose	A8	A11	A15	A11	A15	A20	A11	A15	A20	A11	A15	A20	A15	A20	A15	A20
Id. No.	24184020	24114020	24124020	24115030	24125020	24175020	24116020	24126020	24176020	24116320	24126320	24176320	24128020	24178020	on request	
A	mm	40	40	40	40	40	40	40	40	50	50	50	50	50		
B	mm	139.719	196.869	285.775	196.869	285.775	196.869	285.775	412.775	196.869	285.775	412.775	285.775	412.775	265.775	412.775
C	mm	171.4	235	330.2	235	330.2	235	330.2	463.6	235	330.2	463.6	330.2	463.6	330.2	463.6

Bayonet and camlock spindle adapters are available on request.

JAWS-CATALOG

Request or
download:
www.smw-autoblok.de



- Cycle clamp BB-N / BB-N ES
- Cycle clamp BB-SC

Common parts for all Big Bore air circuits:

V	Non return valve towards the pneumatic system
S	Accumulator (approx. 90 normal liter / 23 gallon)
W	Air service unit 3/4" with filter, dryer, oiler and pressure regulator (0 - 10 bar), min. flowrate 3100 l/min (819 gallon / min); rec. Type: FRL 34S; Riegler & Co. KG, Bad Urach, Germany
D	Silencer 3/4", min. flowrate 15000 l / min (3963 gallon / min); rec. Type: 2311; Festo, Esslingen, Germany
F	Air flow sensor

Used connection parts for time measuring according to page 7:

- Length of hoses from air control to chuck: 3000 mm
- Inside dia. of hoses from air control to chuck 3/4" (19 mm)

Cycle clamp BB-N / BB-N ES

action	Valve Y1	Valve Y2
clamp / unclamp	clamp	unclamp
1. chuck open		○
2. chuck clamp	○	

○ = Valve actuated for jaw movement

NOTE:

- All valves, hoses and fittings must be at least:
 - 1/2" inside dia. per function up to chuck size 600
 - 3/4" inside dia. per function on larger chuck sizes

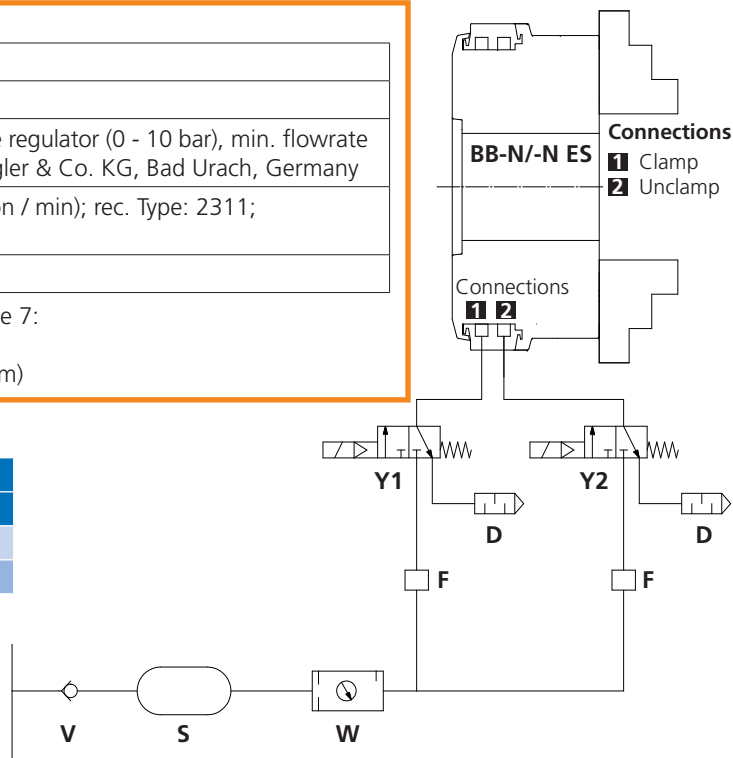

Cycle standard clamp BB-SC

action	Valve Y1	Valve Y2
clamp / unclamp	unclamp	clamp
1. chuck open	X	
2. chuck clamp		○

Cycle step mode / inching BB-SC

action	Valve Y1	Valve Y2
clamp / unclamp	unclamp	clamp
1. chuck open	X	
2. chuck clamp		○
3. step open	○	
4. step close		○

X = Valve permanently actuated

○ = Valve actuated for jaw movement

NOTE:

- All valves, hoses and fittings must be at least 3/4"

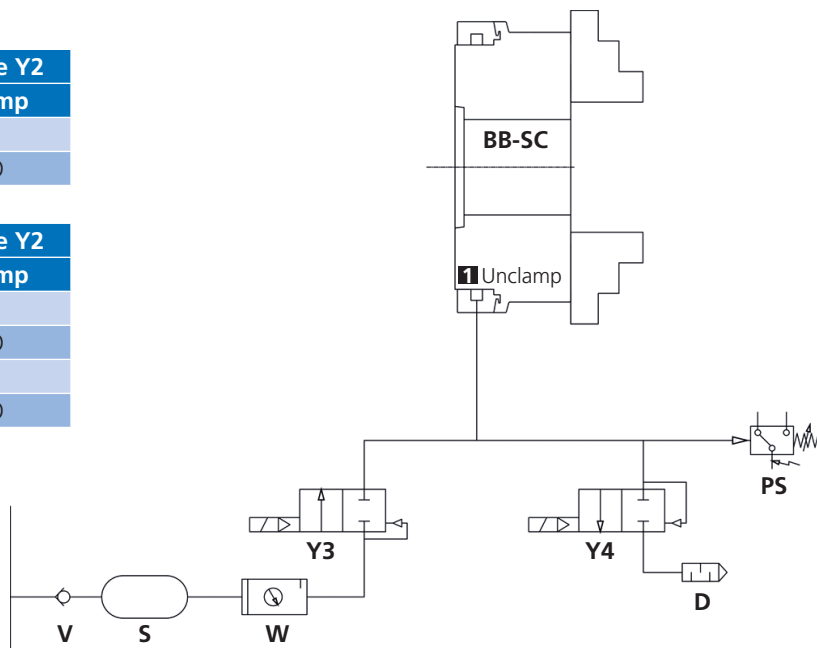

Pneumatic connection parts for BB-N/-N ES and BB-SC:

Y1/Y2	3/2 solenoid valve 1", min. flowrate 3900 l / min (1031 gallon / min); rec. Type: NL6-SOV; Bosch Rexroth, Germany
Y3/Y4	2/2 solenoid valve 3/4", min. flowrate 3100 l / min (819 gallon / min); rec. Type: EGV 121/C78/3/4" BN; AVS Roemer GmbH, Koenigsdorf, Germany
PS	Pressure switch, 0 - 10 bar, 4 - 20 mA; rec. Type: A-10-6-BG410-HD1Z-AA-AGZ; WIKA, Klingenberg, Germany
Q	Quick exhaust valves, min. flowrate 6800 l / min (1765 gallon/min) rec. Type: 573, 1"; Bosch Rexroth, Germany