

AT-PM

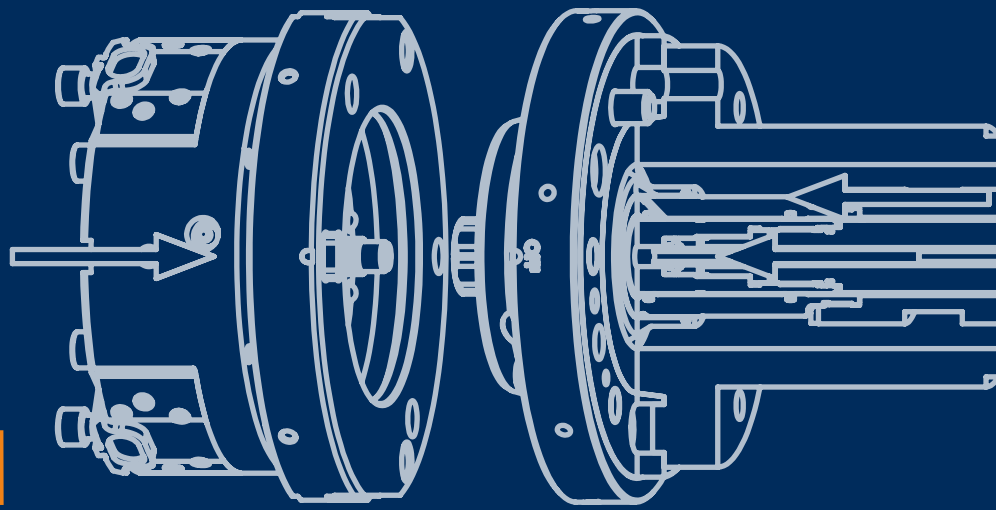

All SMW-Autoblok quick chucks change systems are designed to permit a fast and quick change of chucks on the lathe using a special double cylinder.

CUSTOMER BENEFITS

- ▶ QUICK CHUCKS CHANGE ON LATHE
- ▶ QUICK CHUCKS CHANGE AVAILABLE DIAMETER ON LATHE
- ▶ QUICK CONNECTION TO DOUBLE CYLINDER BETWEEN AUTOMATIC FEEDING
- ▶ PALLET POSITIONING ACCURACY
PALLET < 0,005 mm

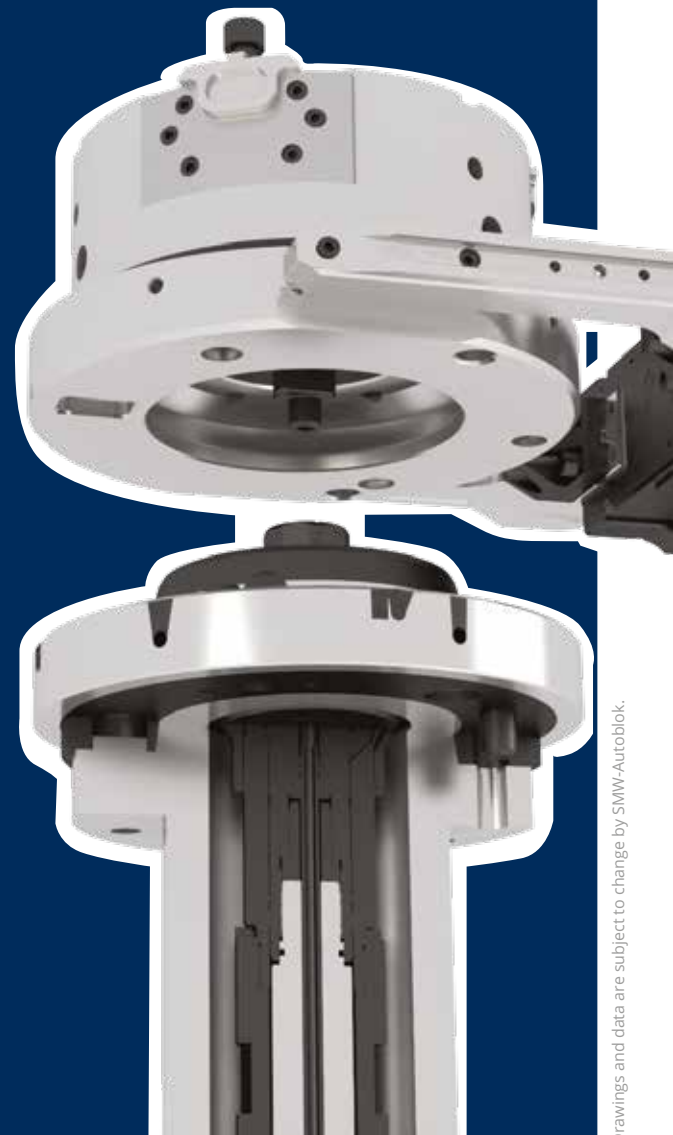

Drawings and data are subject to change by SMW-Autoblok.

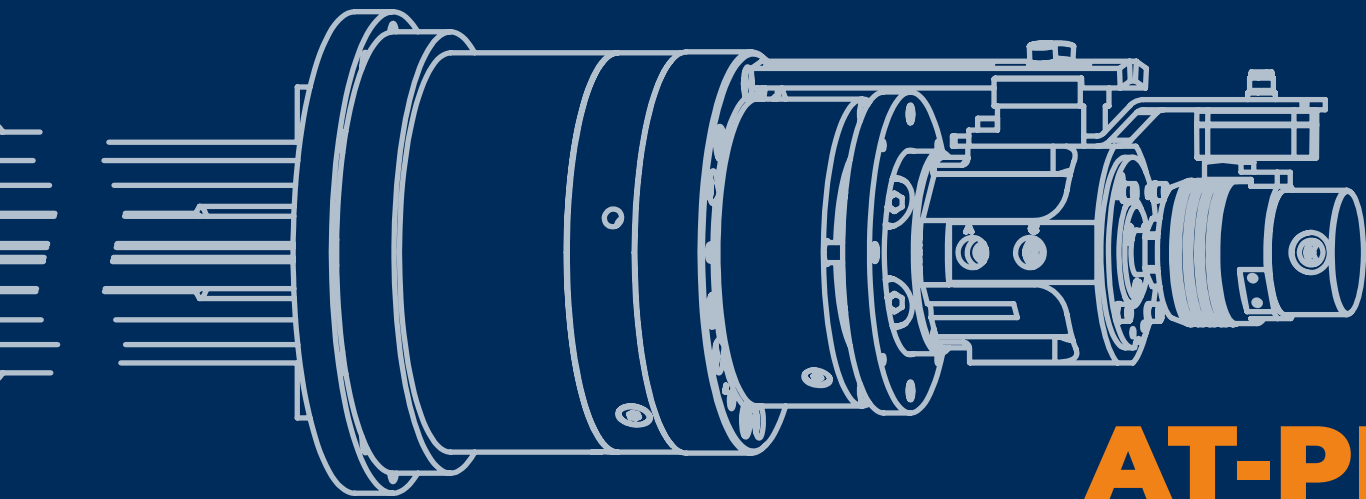

AT-PM

Product type	Size			AT-PM Id. n.	pallets and chucks usable on rotary plate		Air sensing	external draw-bar/operation AT-PM		internal draw-bar/operation CHUCK OR COLLECT	
	200/170	240/220	320/330		∅ pallets /chucks	rpm		max pull-down cylinder	max holding force pallet	max pull-down force cylinder	max pushing force cylinder
ATPM	200/170			65002009	170	5000		30 kN	120 kN	68 kN	40 kN
					210	4000					
					260	3000					
		240/220		65002405	210	4500		30 kN	120 kN	68 kN	40 kN
					260	3500					
					315	2500					
			320/330	65003205	315	2500		40 kN	160 kN	112 kN	65 kN
					400	1600					
					530	900					

DOUBLE PISTON CYLINDERS with 4 safety valves AT-PM control

CUSTOMER BENEFITS

AT-PM actuation +TS and AP chucks

AT-PM actuation + collets

Pallet positioning accuracy < 0,005 mm

PISTON 1

 AT-PM actuation

PISTON 2

 Chuck actuation

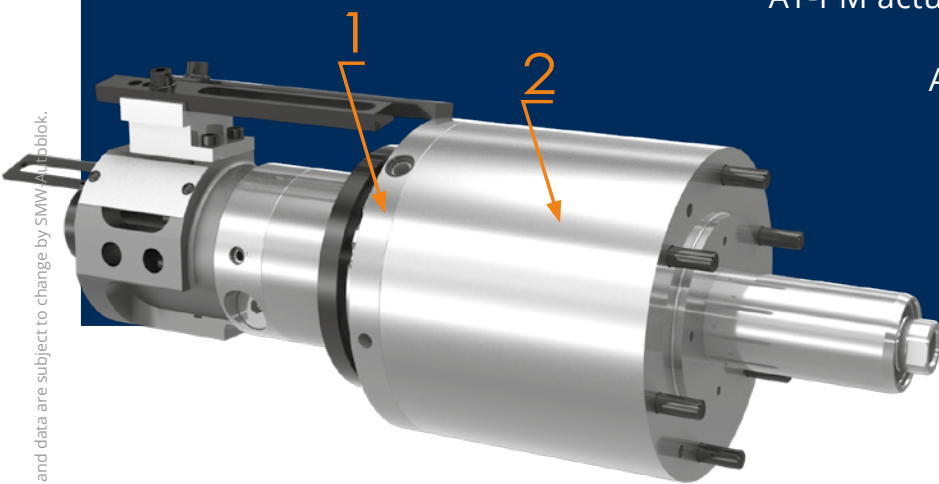

Drawings and data are subject to change by SMW-AUTOBLOK.



AT-PM 200/170

AUTOMATIC CHUCK CHANGE SYSTEM

CHUCKS: Ø170 Ø210 Ø260

Applications/Customer benefits

- Quick chucks change on lathe
- Quick chucks change Ø170 Ø210 Ø250 available diameter on lathe, quick connection to double cylinder between automatic feeding
- Pallet positioning accuracy pallet < 0,005 mm

Technical features

- Hardened materials for high accuracy and durability
- AT-PM operation with hydraulic double cylinder
- Air sensing function for pallet positioning
- Balancing 6.3

AT-PM MODEL	ID.NO.	REPEATABILITY	Ø170 CHUCK MAX RPM	Ø210 CHUCK MAX RPM	Ø260 CHUCK MAX RPM	WEIGHT Kg	EXTERNAL DRAW-BAR/ ACTUATION AT-PM		INTERNAL DRAW-BAR/ ACTUATION CHUCK OR COLLECT	
							MAX PULL-DOWN CYLINDER	MAX HOLDING FORCE PALLET	MAX PULL-DOWN FORCE CYLINDER	MAX PUSHING FORCE CYLINDER
Ø200/170 A6	65002009	0,005 mm	5000	4000	3000	12,5	30 kN	120 kN	68 kN	40 kN

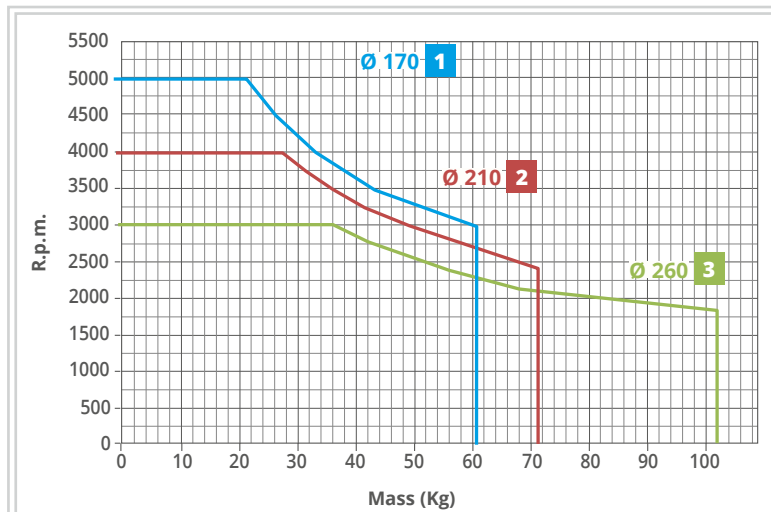

1 (*) Diagram is showing the rpm speed depending from:

- total max weight (pallet + chuck or fixture + workpiece).
- max overall dimension Ø 170 and 190 mm total length

2 (***) Diagram is showing the rpm speed depending from:

- total max weight (pallet + chuck or fixture + workpiece).
- max overall dimension Ø 210 and 220 mm total length

3 (***) Diagram is showing the rpm speed depending from:

- total max weight (pallet + chuck or fixture + workpiece).
- max overall dimension Ø 250 and 250 mm total length

(*) (**) (***) rpm max speed has to be reduced if used the chuck type has a lower rpm speed

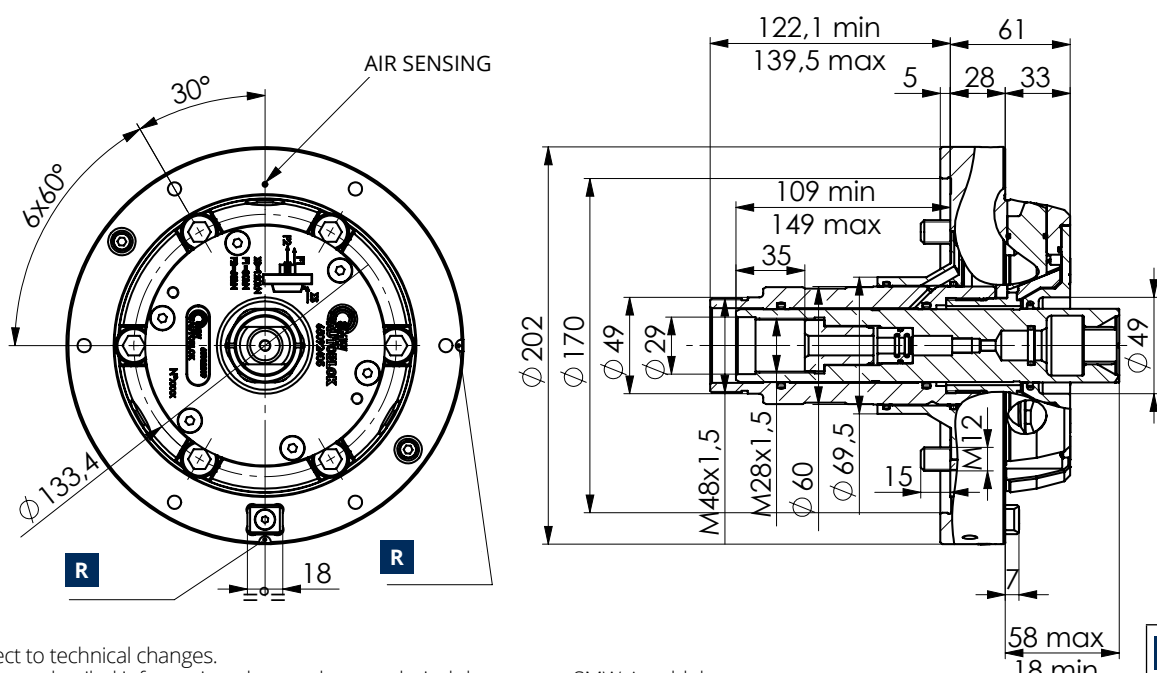

Subject to technical changes.
For more detailed information please ask our technical department SMW-Autoblok.

PALLET FOR QUICK CHUCKS CHANGE SYSTEM AT-PM

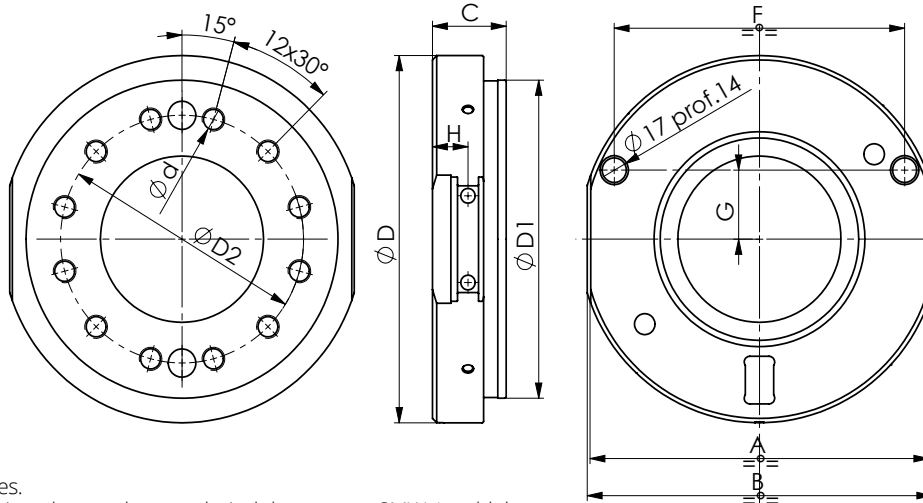

Subject to technical changes.
For more detailed information please ask our technical department SMW-Autoblok.

AT-PM MODEL	PALLET ID.No.	$\varnothing D$ pallet mm	$\varnothing D_1$ mm	$\varnothing D_2$ mm	$\varnothing d$ mm	A mm	B mm	C mm	F mm	G mm	H mm	Weight kg
AT-PM 200/170	65622009	206	140	104,8	M10	190	194	54	166,8	38,9	25	6,6
AT-PM 200/170	65612009	206	170	133,4	M12	190	194	52	166,8	38,9	25	6,3
AT-PM 200/170	65632009	206	220	171,4	M16	190	194	52	166,8	38,9	25	6,8
AT-PM 240/220	65622405	254	170	133,4	M12	239	243	52	204,8	47,8	25	11,8
AT-PM 240/220	65612405	254	220	171,4	M16	239	243	52	204,8	47,8	25	12
AT-PM 320/300	65623205	325	220	171,4	M16	304	308	59	262,8	61,3	25	20
AT-PM 320/300	65613205	325	300	235	M20	304	308	54	262,8	61,3	25	18,7
AT-PM 320/300	65633205	378	380	330,2	M24	345	349	55	262,8	61,3	25	31

PALLET SMF

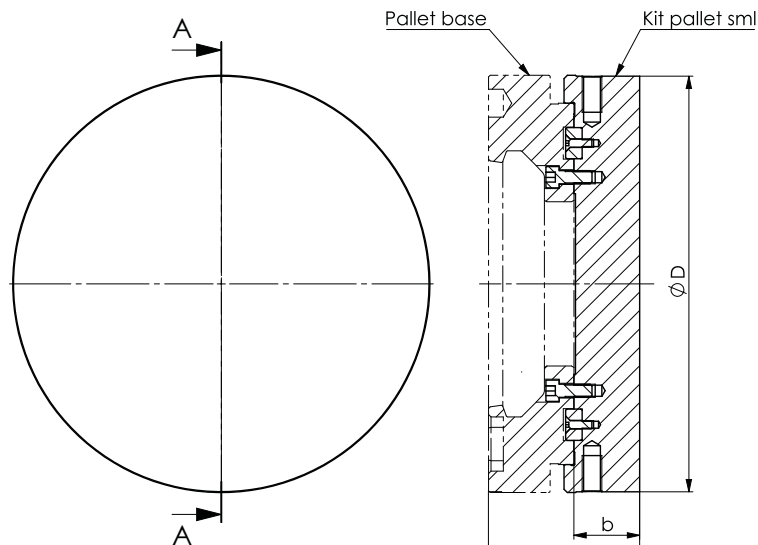

Subject to technical changes.
For more detailed information please ask our technical department SMW-Autoblok.

AT-PM MODEL	ID.No. KIT PALLET SMF	ID.No. PALLET BASE	$\varnothing D$ mm	b mm	b1 mm	Weight kg
AT-PM 200/170	65502009	65632009	254	40	92	16,5
AT-PM 240/220	65502009	65612405	254	40	92	16,5
AT-PM 320/300	65503205	65613205	354	40	94	32

EXAMPLE OF EXPANDING MANDRELS USABLE ON AT-PM
ask more details to SMW-Autoblok technical office department

EM-A model
pull-down
expanding mandrels



personalized
connection

EM-B model
expanding mandrels



personalized
connection

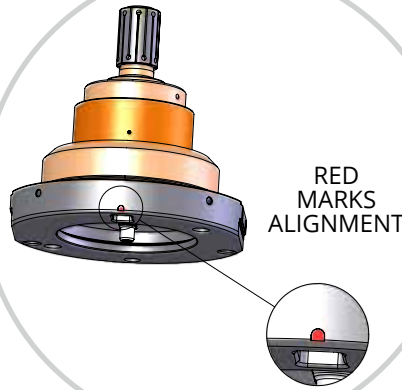

RED
MARKS
ALIGNMENT



personalized
connection



personalized
connection

EM-AL model
pull-down expanding
mandrels-body lengthened

KSZ-AZ model
draw collet chucks

EXAMPLE OF SELF-CENTERING CHUCKS USABLE ON AT-PM
watch the video using QR code

STEP1



STEP2



STEP3



STEP4

QUICK CHUCKS CHANGE SYSTEM AT-PM

pallet connecting instructions

