

PRS

Robot quick change systems

CUSTOMER BENEFITS

- ▶ Quick and safe gripper change
- ▶ ISO flange
- ▶ Pneumatic drive
- ▶ Self-locking by spring tension (turbo)
- ▶ Wear-free and maintenance-free contactless transmission system for energy and signals (optional)
- ▶ Integrated interlock status query

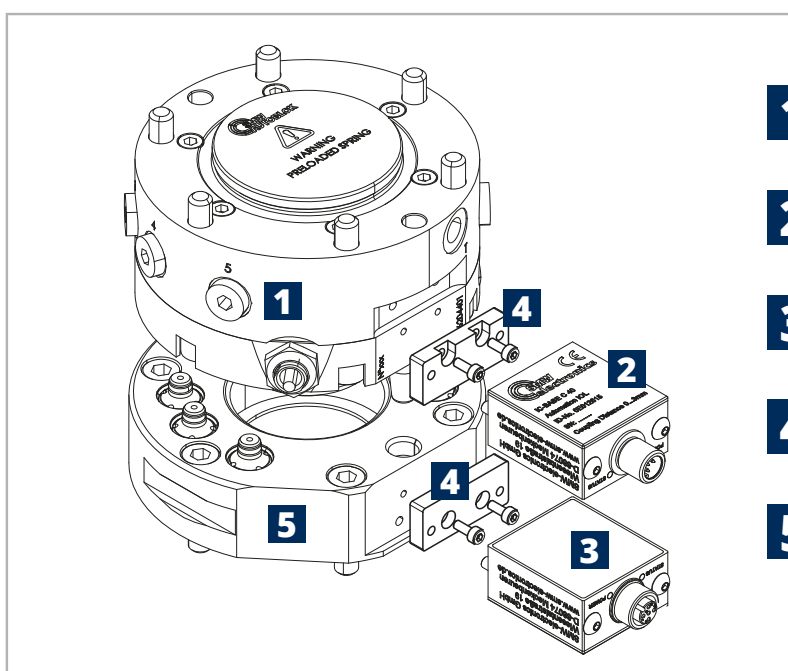

- 1** QUICK CHANGE MODULE ROBOT SIDE
- 2** CONNECTION MODULES / INDUCTIVE COUPLING BASE UNIT
- 3** CONNECTION MODULES / INDUCTIVE COUPLING REMOTE UNIT
- 4** MOUNTING KIT
- 5** QUICK CHANGE MODULE TOOL SIDE



SMW-Autoblok TYPE	Size					Id.n. without pallet	n. pneumatic connections		Stroke control: Inductive and analogic proximity- based	Pneumatic opening	Springs clamp + TURBO	Electric signal interface module (optional)
	55	85	110	160	240		6	7				
PRS	55					46204550						
		85				46204600						
			110			46204400						
				160		46204320						
					240	46204500						



CLAMPING EXAMPLE

Id.n. PRS	Max liftable weight	Repeatability 0,015 mm	Pull-down force		Pressure		Weight
			spring	spring + TURBO	open	TURBO	
46204550	20 kg	0,015	70 daN	340 daN	6 bar	6 bar	0,5 kg
46204600	50 kg	0,015	200 daN	1000 daN	6 bar	6 bar	1,3 kg
46204400	75 kg	0,015	250 daN	1400 daN	6 bar	6 bar	3 Kg
46204320	150 kg	0,015	400 daN	1900 daN	6 bar	6 bar	6 Kg
46204500	500 kg	0,015	1250 daN	7600 daN	6 bar	6 bar	16 Kg

85 PRS PNEUMATIC HEAD CHANGING

- Pneumatic operation
- Spring clamping + TURBO

Function

Automatic head/gripper changing system for robots

Technical features

- Body and internal mechanism case-hardened for higher rigidity and longer life
- Inductive and analogic proximity-based stroke control system (as standard)
- Pneumatic opening

- Spring clamp + TURBO
- Electric signal interface module (optional)
- n.6 pneumatic connectors for media trasmission between the changing unit and the gripper mounting on it.
- hydraulic connectors are not expected

Model	Id.n. (without pallet)	Max liftable weight	Repeatability	pneumatic connections n.	Pull down force		Pressure		Weight
					spring	spring+TURBO	open	TURBO	
85 PRS	46204600	50 kg	0,015 mm	6	2 kN	10 kN	6 bar	6 bar	1,3 kg

Model	Pallet	Weight
HEAD CHANGING PALLET 85PRS	46204615	0,7 kg

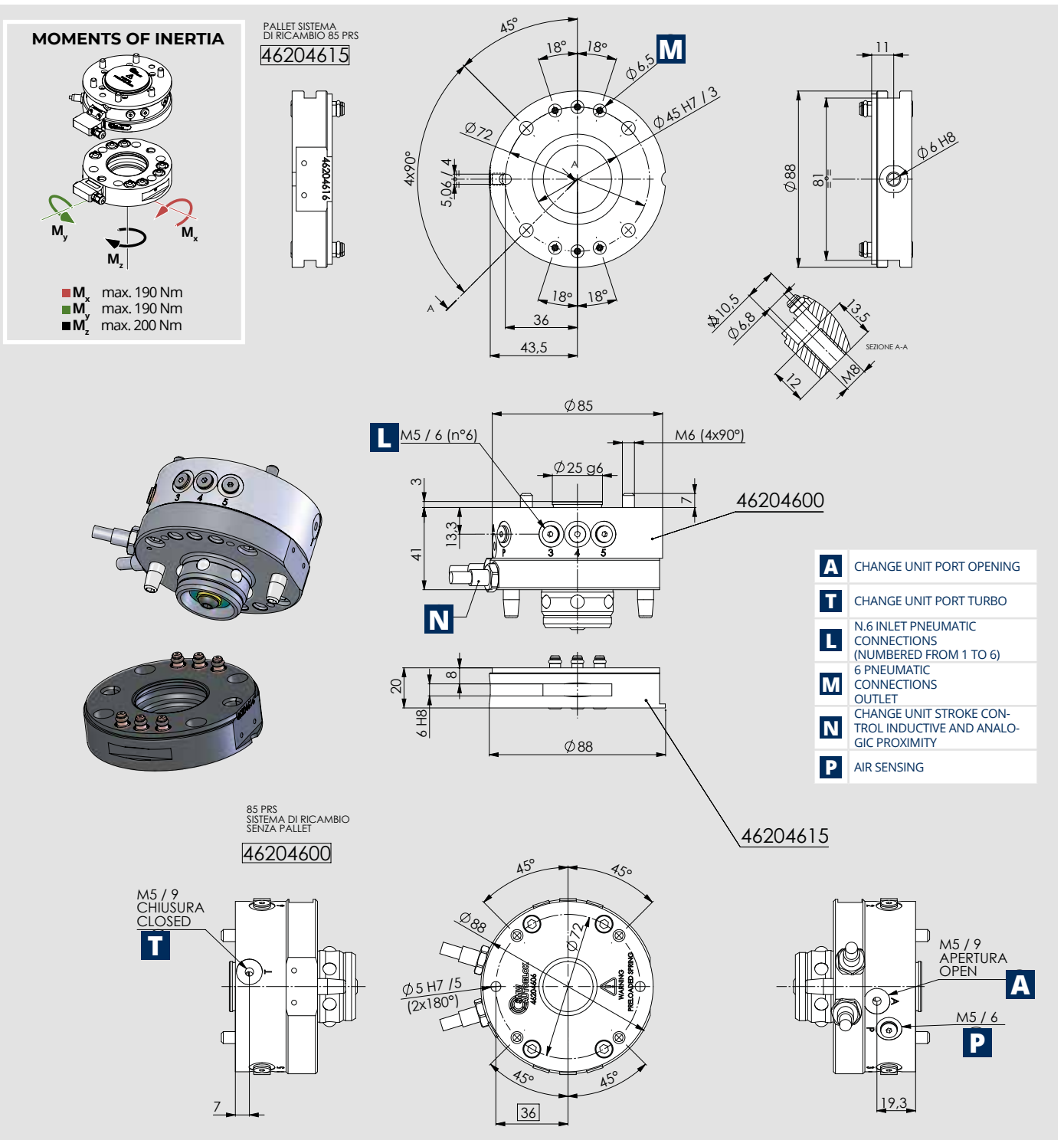

FLANGE GROUP

for head changing 85 PRS

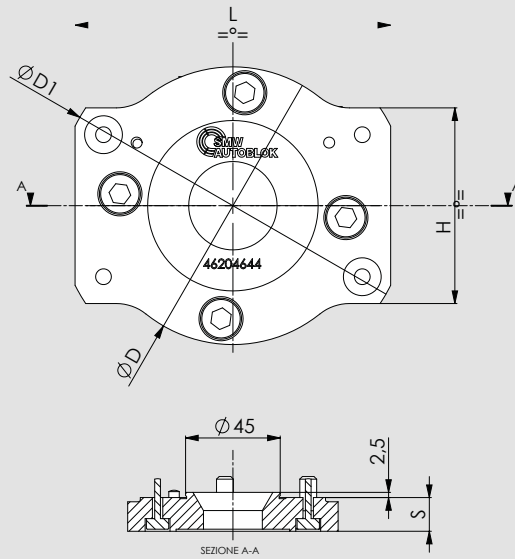

FLANGE KIT ID.No.	D	D1	S	H	L	WEIGHT kg	GRIPPER TYPE MONTABLE
46204640 FLANGE KIT 85PRS/2PXM 125	88	130	18	78	122	0,4	2PXM 125 *
46204642 FLANGE KIT 85PRS/PL - 2PXS 100	88	88	16	/	/	0,3	PL 100 - 2PXS 100 *
46204644 FLANGE KIT 85PRS/PP - PL 125	88	112	16	62	100	0,3	PL 125 - PP 125 *
46204646 FLANGE KIT 85PRS/3MN - 3PXS 100	104	104	16	/	/	0,4	3MN 100 - 3PXS 100 **
46204648 FLANGE KIT 85PRS/3MN - 3PXM 125	118	118	16	/	/	0,5	3MN 125 - 3PXM 125 **

