

ROTARY PLATE

Pallet/Tooling
fast set-up on
turning spindles

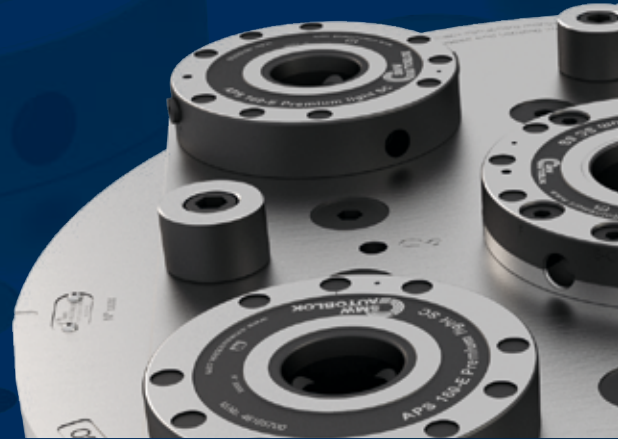

CHUCK

PALLET

**ROTARY
PLATE**

ADAPTOR



ROTARY PLATE

Rotating table which holds the workpiece in place during operations

CUSTOMER BENEFITS

- PALLET/TOOLING FAST SET-UP
- CHUCKS FAST SET-UP ON TURNING SPINDLES, MANUAL CONNECTION (WITH SCREW) BETWEEN CHUCK AND CYLINDER FOR MANUAL ROTARY PLATE
- TOOLING PRESENCE WITH AIR SENSING FUNCTION FOR AUTOMATIC ROTARY PLATE
- SC STROKE CONTROL FUNCTION
- POSITIONING ACCURACY < 0,005 mm
- 3 PNEUMATIC FEEDINGS (6 BAR) AVAILABLE ON PALLET FOR AUTOMATIC ROTARY PLATE+3FEEDINGS

TECHNICAL FEATURES

- CASE HARDENED MAIN COMPONENTS TO ASSURE BETTER ACCURACY AND LONG OPERATING LIFE
- PNEUMATIC OPENING
- CLOSING BY SPRING + TURBO FUNCTION
- OPENING/CLOSING APS MANUALLY OPERATED
- OPENING/CLOSING APS AUTOMATICALLY OPERATED
- G6.3 BALANCING DEGREE

Types	Size								Manual operation of APS modules	Automatic operation of APS modules	Automatic operation of APS modules + 3 feedings	APS central size		APS lateral size		Ø pallets and chucks usable on rotary plate
	202	260	330	420	520	650	1000	1400				190	250	140	160	
MANUAL ROTARY PLATE	202											1				170-210
		260											1			210-250-315
			330											3		250-315
				420										4		400
					520							1			4	500-650
						650						1			4	650-800
							1000						1		6	1000-1250
AUTOMATIC ROTARY PLATE								1400				1		8		1400-1600-1800
	202											1				170-210
		260											1			210-250-315
			330											3		250-315
				420										4		400
					520							1			4	500
						650						1			4	650-800
AUTOMATIC ROTARY PLATE + 3 FEEDINGS	202											1				170-210
		260											1			210-250-315
			330											3		250-315
				420										4		400
					520							1			4	500
						650						1			4	650-800

Drawings and data are subject to change by SMW-Autoblok.

MANUAL OPERATION

APS MODULES

3
a



Drawings and data are subject to change by SMW-Autoblok.

ROTARY PLATE $\varnothing 1000$

with APS 250 and 6 APS 160 manual operation

Manual tooling fast set-up for $\varnothing 1000$ and $\varnothing 1250$ pallets and chucks



N. 2 PNEUMATIC CONNECTIONS FOR MANUAL OPENING AND TURBO COMMAND

Applications/Customer Benefits

- Pallet/Tooling fast set-up
- Chucks fast set-up $\varnothing 1000$ and $\varnothing 1250$ on turning spindles, manual connection (with screw) between chuck and cylinder
- Positioning accuracy < 0,005 mm

Technical features

- Case hardened main components to assure better accuracy and long operating life
- Pneumatic opening
- Closing by spring + Turbo function
- Opening/closing manually operated
- G6.3 balancing degree

ROTARY PLATE MODEL	ID.NO.	REPEATABILITY	CLAMPING FORCE BY TURBO FUNCTION AT 6 bar	MAX PRESSURE OPENING / CLOSING	WEIGHT Kg	CHUCK FEATURES			
						DRAW BAR MAX PULLING FORCE	DRAW BAR MAX PUSHING FORCE	$\varnothing 1000$ CHUCK MAX RPM (*)	$\varnothing 1250$ CHUCK MAX RPM (**)
$\varnothing 1000$ MANUAL	46220030	0,005 mm	235 kN	6 bar	400	180 kN	110 kN	630	500

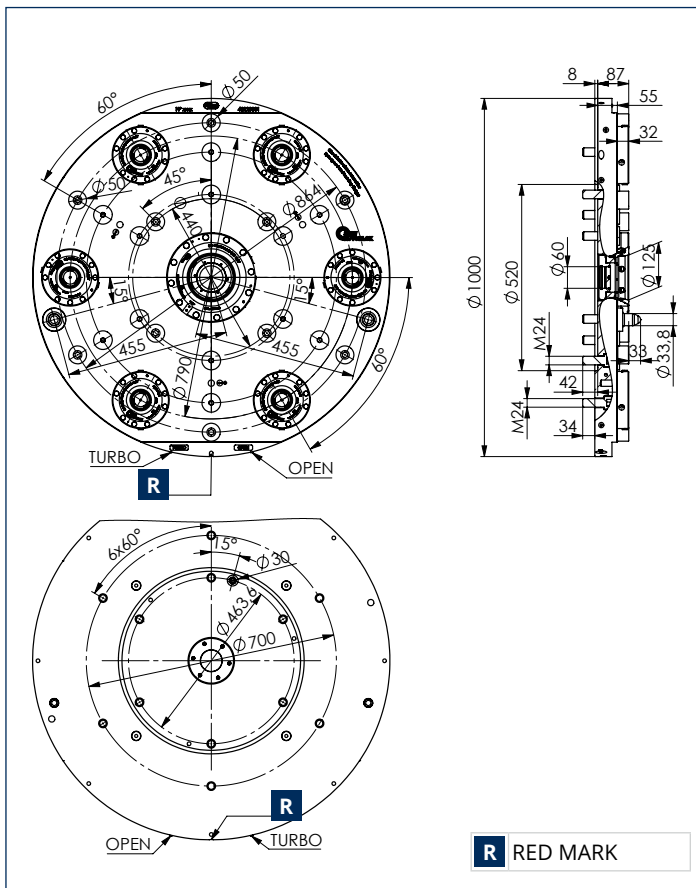

Weight/Speed diagram

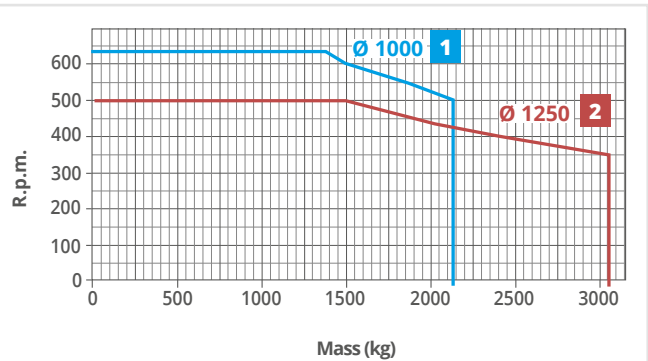

- (*) Diagram is showing the rpm speed depending from:
 - total max weight on rotary plate (pallet + chuck or fixture + workpiece).
 - max overall dimension on rotary plate $\varnothing 1000$ and 450 mm total length
- (**) Diagram is showing the rpm speed depending from:
 - total max weight on rotary plate (pallet + chuck or fixture + workpiece).
 - max overall dimension on rotary plate $\varnothing 1250$ and 450 mm total length

(*) (**) rpm max speed has to be reduced if used chuck type has lower rpm speed

ROTARY PLATE Ø1000: AVAILABLE PALLETS

46220310

278
kg

Pallet SMF
Ø1000 x 45

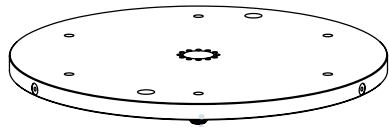

46220320

435
kg

Pallet SMF
Ø1250 x 45

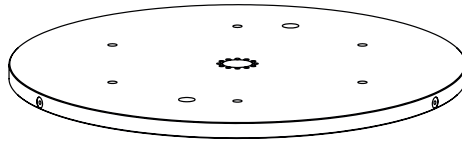

46220070

230
kg

Pallet Ø520
for PTF Ø1000 Ø1250
for HG Ø800

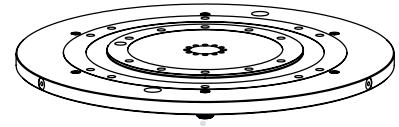

G1/8 71612801 female quick
connection for pneumatic
manual operation

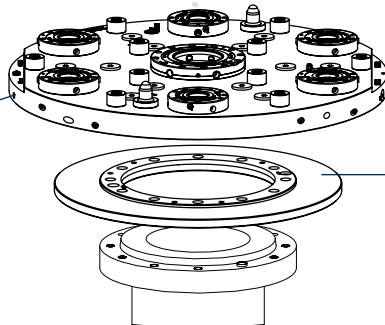

46220030

Manual Ø1000 Rotary Plate
+ APS 250
+ 6 APS 160 module

Special flange or direct
assembly on machine spindle

NOTE: for 1000 HG chuck,
special pallet to be required

ROTARY PLATE Ø1000: USABLE CHUCKS SCHEME

1000 IEP

1250 IEP

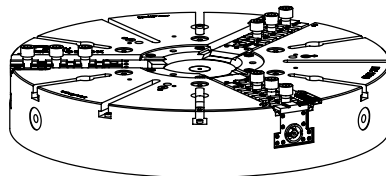

1000 IN 3-4-6 jaws

1250 IN 3-4-6 jaws

1000 IR 3-4-6 jaws

1250 IR 3-4-6 jaws

Special connection group



46220070

230
kg

Pallet Ø520

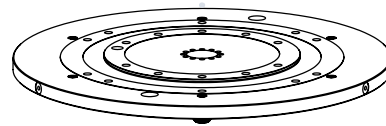

G1/8 71612801 female quick
connection for pneumatic
manual operation

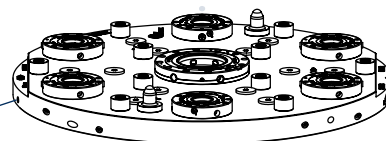

46220030

Manual Ø1000 Rotary Plate
+ APS 250
+ 6 APS 160 module

Special flange or direct
assembly on machine spindle

DRAW BAR

NOTE: all indicated chucks can have air sensing function as
optional

Recommended cylinders for ROTARY PLATE

Manual pallet fast set-up with chucks.
Connection between the chuck and the draw bar is made by screw.

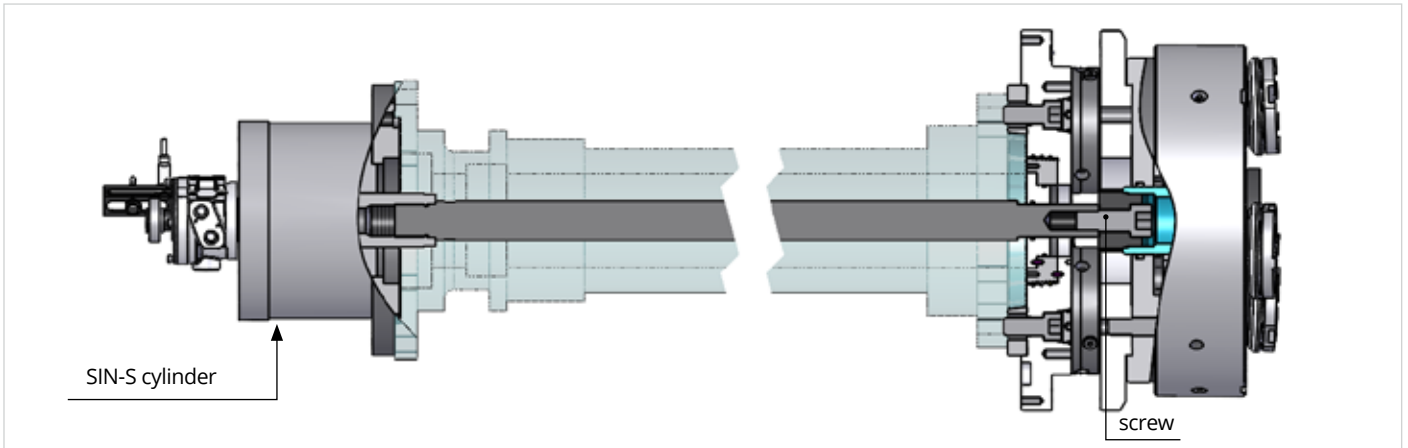

RECOMMENDED CYLINDERS								
ROTARY PLATE TYPE	TS / TX	➔ SIN	AP	➔ SIN	IR	/ IN	/ IEP	➔ SIN
Ø202	170	85 SIN-S	170	100 SIN-S	-	-	-	-
	210	100 SIN-S	210	125 SIN-S	-	-	-	-
Ø260	210	100 SIN-S	210	125 SIN-S	-	-	-	-
	210-315	125 SIN-S	250-315	150 SIN-S	-	-	-	-
Ø330	250-315	125 SIN-S	250-315	150 SIN-S	-	-	-	-
Ø420	400	150 SIN-S	400	175 SIN-S	-	-	-	-
Ø520	530-650	150 SIN-S	500-630	200 SIN-S	-	-	-	-
Ø650	650	175 SIN-S	630-800	200 SIN-S	-	-	-	-
Ø1000	-	-	-	-	1000-1250	1000-1250	1000-1250	200 SIN-S (*)
Ø1400	-	-	-	-	1400-1600-1800	-	1400-1600	200 SIN-S (*)

(*) 1000/1250/1400/1600/1800 IR/IN chucks have 50 mm reduced stroke of the wedge if used by the SIN-S 200 cylinder.

Manual tooling fast pallets set-up

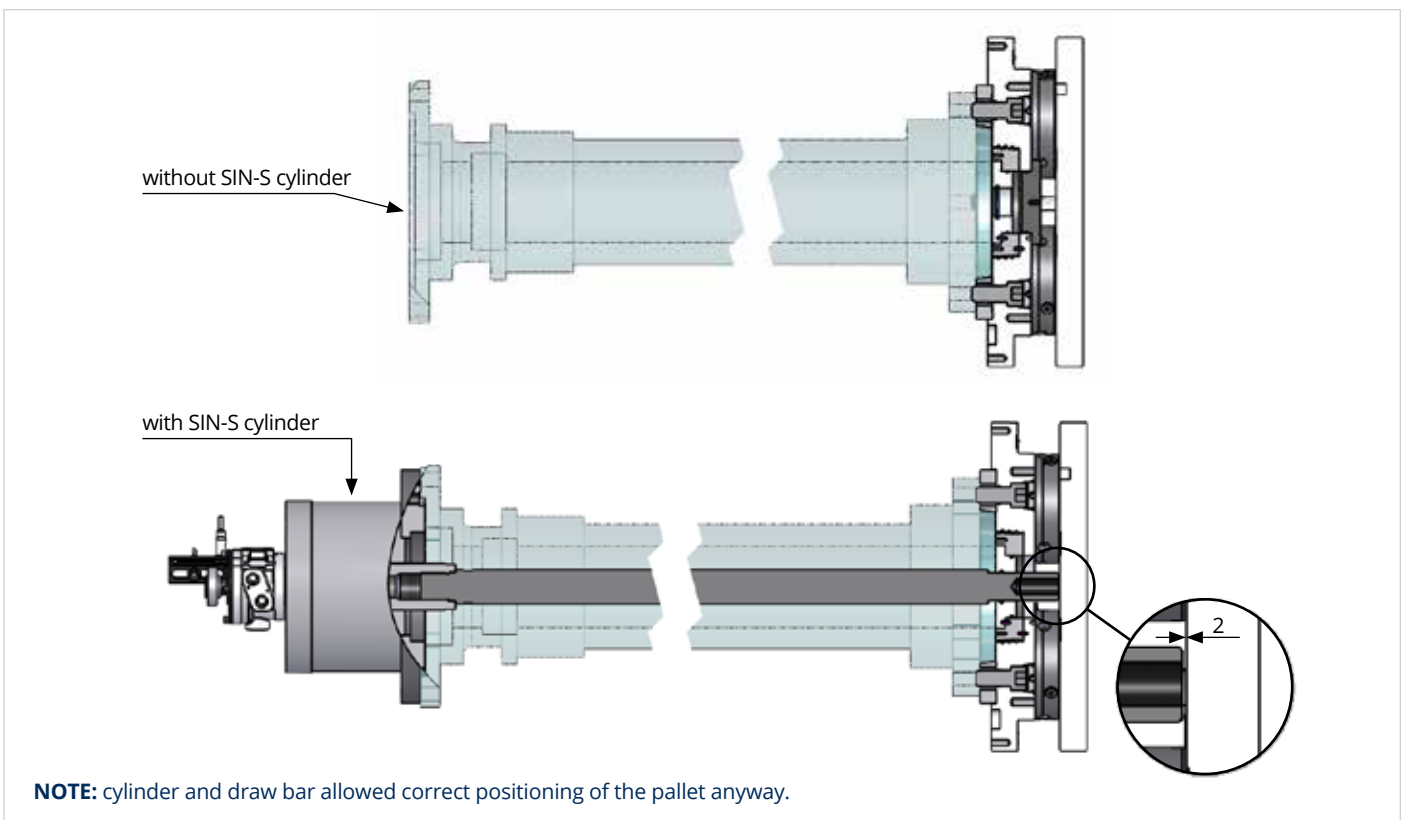

NOTE: cylinder and draw bar allowed correct positioning of the pallet anyway.

ROTARY PLATE ASSEMBLY LINE

Automatic operation APS modules

Manual or automatic pallet tooling fast set-up

Pallet  FOR EACH SIZE, CHECK RELATED PALLETS

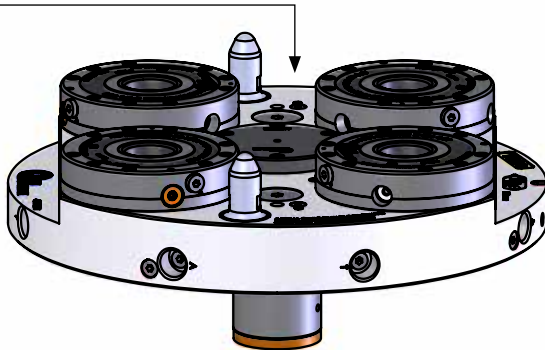

Mod. Id.No. AUTOMATIC ROTARY PLATE

Ø202	46220460
Ø260	46220500
Ø330	46220360
Ø420	46220400
Ø520	46220090
Ø650	46220140

ISO-A flange  [VIEW ACCESSORIES](#)

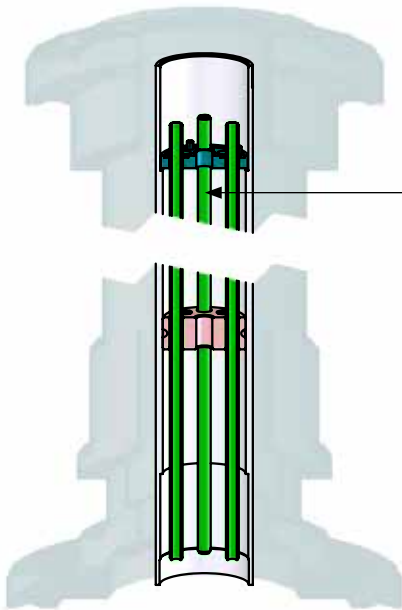

Pipe bundle

(to customize for each machine tool specifically)



Manifold flange

(to customize for each machine tool specifically)

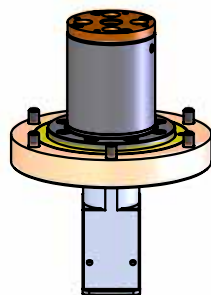

60580011  [VIEW ACCESSORIES](#)

3-pneumatic feedings manifold

PIPE BUNDLE for Automatic operation of APS modules

PIPE BUNDLE assembly from ROTARY PLATE side

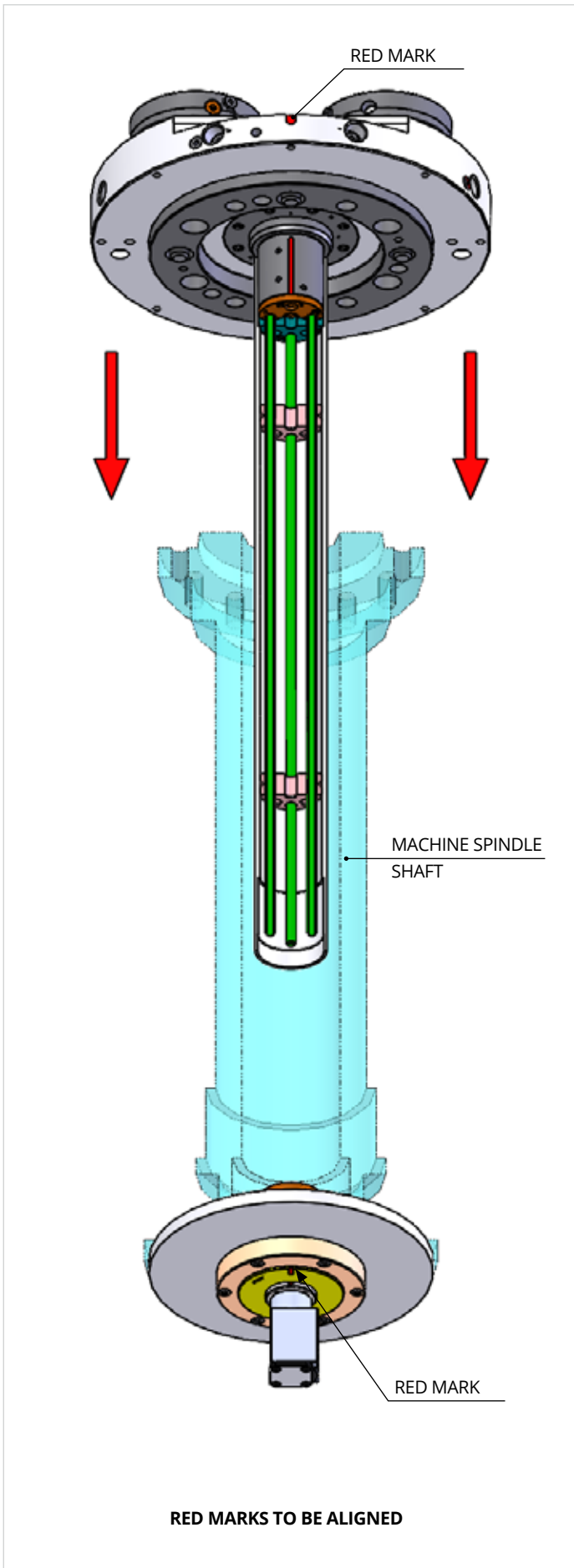

PIPE BUNDLE assembly from MANIFOLD side

