

CENTCO4

4-jaw chuck

In the beginning the jaw pairs **Z1** and **Z2** only apply a centering-force that is necessary to center the workpiece. Only if both jaw pairs **Z1** and **Z2** are in contact with the workpiece, the clamping force necessary for machining is applied.

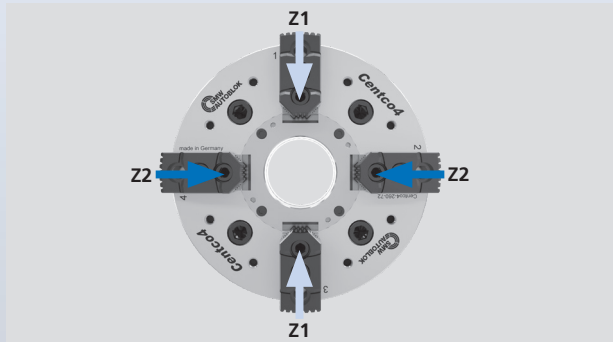

2+2 self centering + compensating clamping

of round,

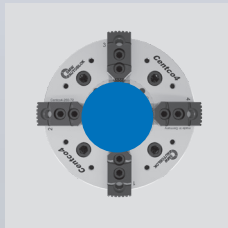

thin-walled,

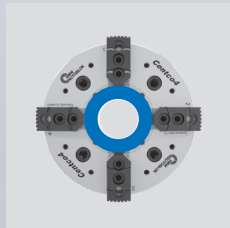

irregular shaped and

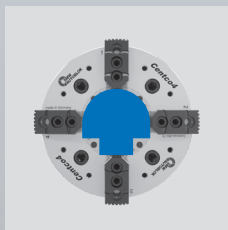

square / rectangular workpieces

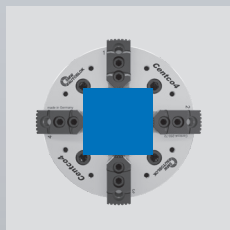

Examples for workpieces



POSSIBLE COST SAVINGS

calculation example

3-jaw chuck		Centco4	
normal jaw chuck	€/set	1x Standard jaws	€/Satz
■ 1x Special jaws	1.500,-€	1x Standard jaws	500,-€
● 1x Standard jaws	375,-€	1x Standard jaws	500,-€
▲ 1x Special jaws	1.750,-€	1x Standard jaws	500,-€
○ 1x Special jaws	2.000,-€	1x Standard jaws	500,-€
Total		Total	
at 1 set of jaws respectively	5.625,-€	at 1 set of jaws respectively	2000,-€
Cost savings		Cost savings	
at 1 set of jaws	0 €	at 1 set of jaws	3.625,-€

Centrifugal force compensation for highest speeds

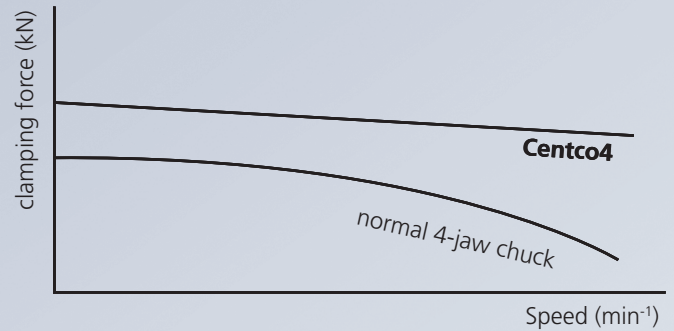

Actuation by central Piston via standard cylinder

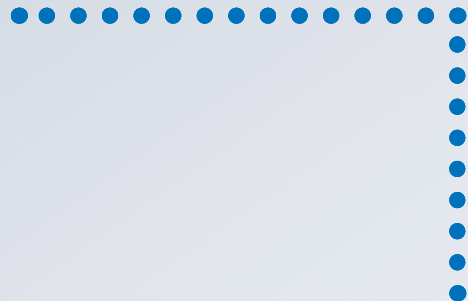

2+2 self centering and compensating clamping



Serration optional
Inch or metric

Clamping glossary

2+2 self centering-compensating clamping: Work pieces need to be centered when clamping. When using 3 jaw chucks, this is carried out via a mechanical synchronizing of the 3 jaws to one common center. A self centering 4 jaw chuck which is used for different work piece geometries is creating 2 separate centers via the 2 opposed jaw sets. The mechanical synchronizing is causing a redundant positioning, which affects the clamping negatively.

The **Centco4** with its 2+2 self centering-compensating clamping centers the work piece with 2 independent axes. The self centering 2 axes work independent from each other, and thus can reach one common center. This works with any work piece geometry or tolerance. The grip force is only built up, after both jaw axes have reached their common center. This guaranties a very sensitive and high accurate clamping at any grip force and best machining results.

Actuation by central piston: In the **Centco4** 2+2 self centering-compensating chuck the 2 self centering axes are operated via 1 common central actuating piston. This allows the use of a standard single piston cylinder. Compared to chucks with double piston drive, it saves the use of an expensive double piston cylinder, the additional hydraulic valves and the additional M-codes.

Centrifugal compensation: The rotation of a chuck results in centrifugal forces that act onto the master jaws and the top jaws. It reduces the static grip force, and thus reduces the dynamic chip removal. The centrifugal force system of the **Centco4** reduces this effect, and thus improves the dynamic chip removal, the safety and the roundness of the work pieces.

Direct pressure lubrication system: In a pressure lubrication system all loaded areas are directly lubricated via direct channels. Used lubricant is directly replaced by new lubricant. Compared to open lubrication systems it reduced the amount of lubricant needed, increases the lubrication intervals and avoids tribo corrosion

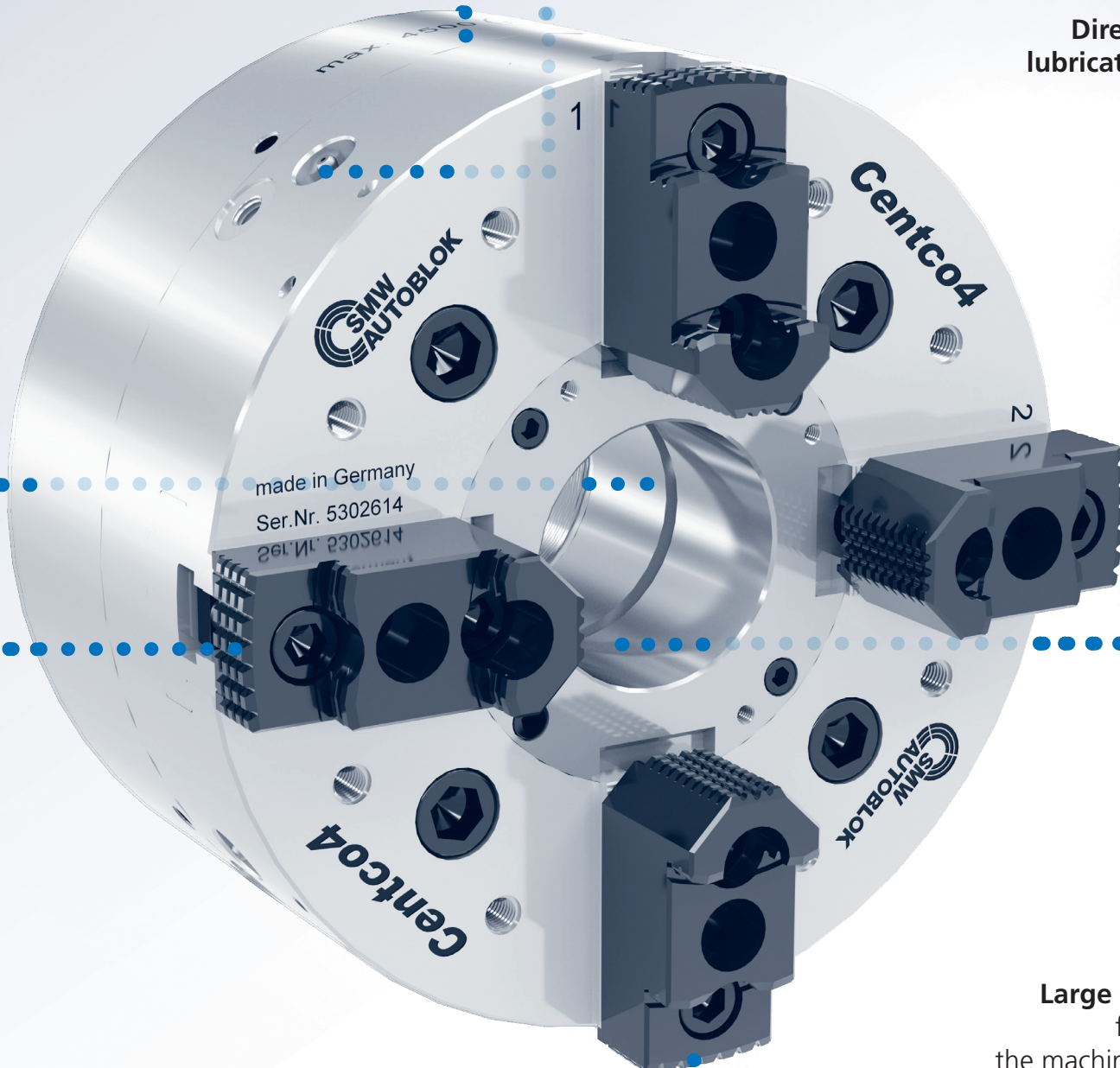

Direct pressure lubrication system

Large passage, full use of the machine spindle

- 2+2 self centering
- Independent self centering clamping in 2 axis
- Centrifugal force compensation

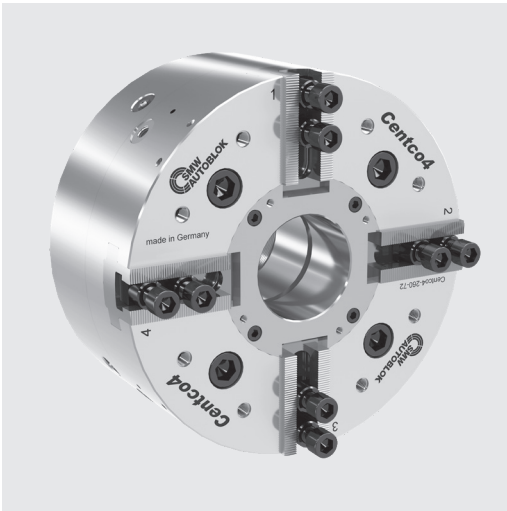

Application/customer benefits

- Independent self centering clamping in 2 axis via 1 central actuating mechanism
- Mechanical centering of the workpiece
- Standard cylinder can be used for actuating
- Clamping of every workpiece geometry possible
- Less workpiece deformation compared to 3-jaw chucks
- Long lifetime due to case hardened parts
- Large range of standard top jaws
- Suitable for OD and ID clamping

Technical features

- Centrifugal force compensation
- Optimized lubrication system
- Large through-hole
- Jaw interface inch / metric

Standard equipment

- 4-jaw chuck,
- 8 pieces T-nuts and bolts

Ordering example

- 4-jaw chuck
- Centco4-260-7-Z-220

Function / Application examples

2+2 self centering and compensating clamping*

In the beginning the jaw pairs **Z1** + **Z2** only apply a force that is necessary to center the workpiece. Only if both jaw pairs **Z1** and **Z2** are in contact with the workpiece, the grip force necessary for machining is applied.

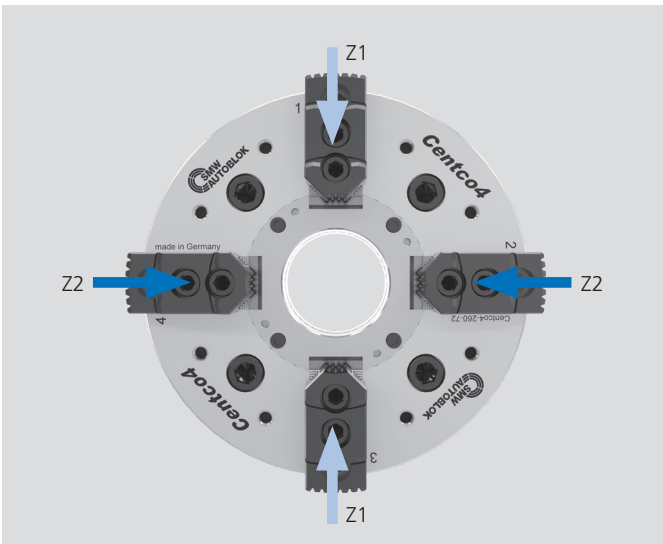

2+2 self centering and compensating clamping of round or thinwalled workpieces

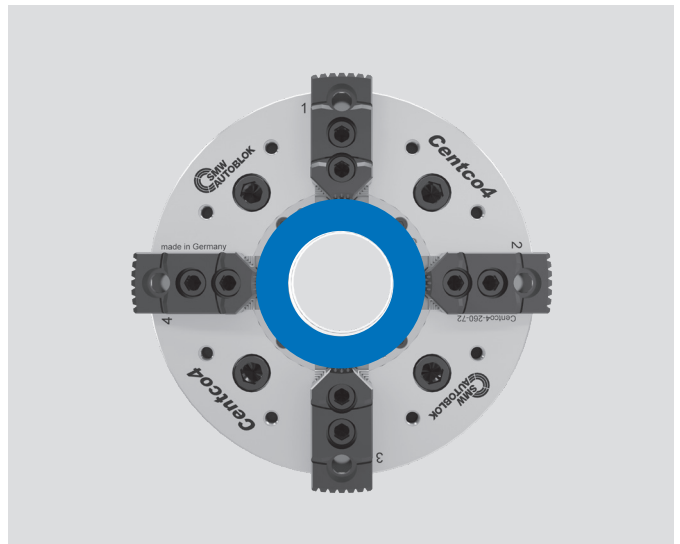

2+2 self centering and compensating clamping of rectangular or square workpieces

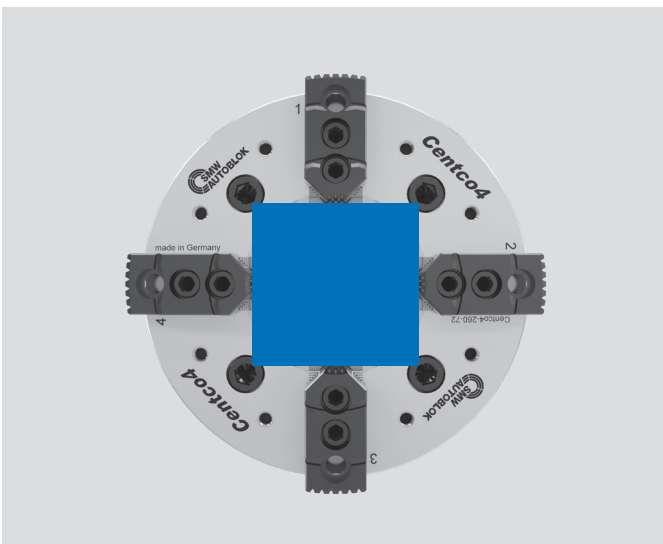

2+2 self centering and compensating clamping of unshaped workpieces

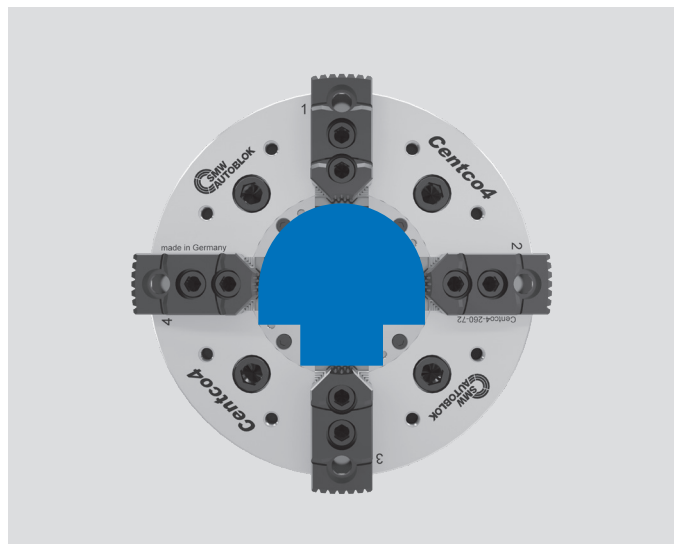

* **Z1**: Self centering clamping axis 1 / **Z2**: self centering clamping axis 2.
Z1 is compensating to **Z2**.

4-jaw chuck

- 2+2 self centering
- Independent self centering clamping in 2 axis
- Centrifugal force compensation

Centco4

INCH / METRIC
SERRATION

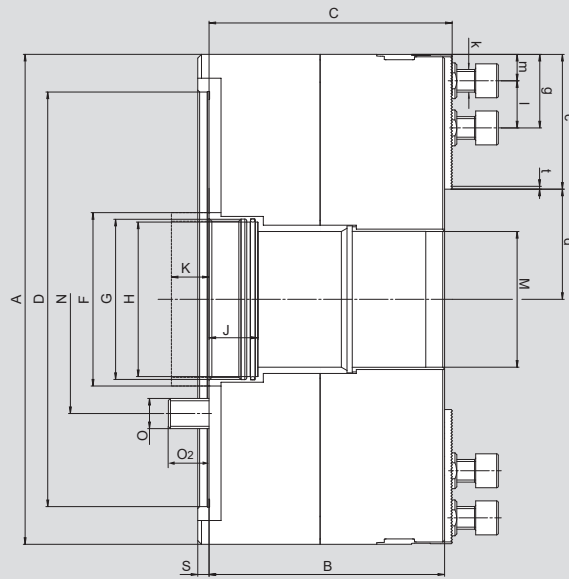
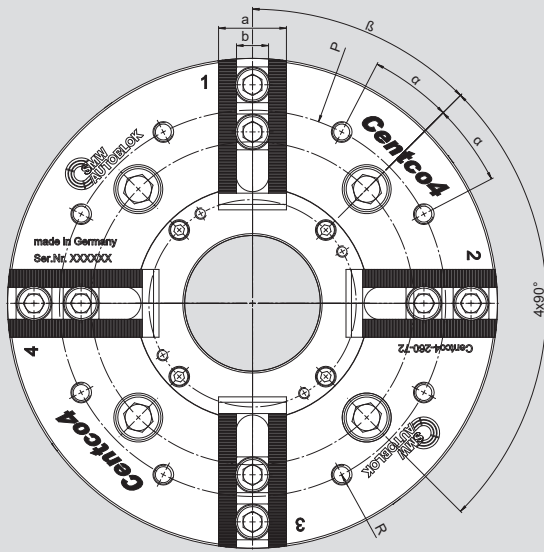

Subject to technical changes.
For more detailed information please ask our customer service.

SMW-AUTOBLOK Type		Centco4 210-52	Centco4 260-72	Centco4 315-92	Centco4 400-112	Centco4 400-112	Centco4 500-155	Centco4 630-165
Mounting		Z170	Z220	Z300	Z300	Z380	Z380	Z380
Outside diameter	A	210	260	315	400	400	500	630
	B	108.5	125	134	146	146	156	156
	C	110.5	129	138	148	148	159	159
Diameter Mounting	D H6	170	220	300	300	380	380	380
	F	68	92	115	142	142	178	188
Piston thread / depth	G	M60 x 2 / 20	M85 x 2 / 20	M105 x 2 / 20	M125 x 2 / 28	M125 x 2 / 28	M165 x 2 / 28	M175 x 2 / 28
Centering draw tube	H H7	57	82	102	122	122	162	172
Face contact draw tube	J	30	30	30	38	38	38	38
Piston stroke	K	17	20	23	25	25	30.5	30.5
Through-hole	M H7	52	72	92	112	112	155	165
Bolt circle	N	133.4	171.4	235.0	235.0	330.2	330.2	330.2
Fixing bolt	O	M12	M16	M20	M20	M24	M24	M24
	O2	19.5	22	29	25	29	34.5	34.5
	P	170	205	260	280	280	410 / 280	585 / 420 / 300
Thread / depth	R	M8 / 12	M10 / 21	M10 / 15	M10 / 15	M10 / 15	M10 / 15	2xM16/24-M12/18
	S	5	6	6	6	6	6	6
Base jaw width	a	35	36	40	45	45	60	60
Groove width inch serration	b H7	14	17	17	21	21	25.5	25.5
Groove width metric serration	b H7	14	14	14	-	-	-	-
	c	60	71.5	91	117.5	117.5	142.5	202.5
Jaw position max.	d	45	58.5	66.5	82.5	82.5	107.5	112.5
Spacing max. / min.	g	47 / 22	58 / 25	78 / 25	104 / 35	104 / 35	115 / 44	175 / 44
Bolt ISO 4762 12.9 inch serration	k	M10	M12	M12	M16	M16	M20	M20
Bolt ISO 4762 12.9 metric serration	k	M12	M12	M12	-	-	-	-
Spacing min.	l	16* / 23**	19	19	25	25	30	30
Spacing min.	m	6	6	6	10	10	14	14
Inch serration	t	1/16" x 90°	1/16" x 90°	1/16" x 90°	1/16" x 90°	1/16" x 90°	3/32" x 90°	3/32" x 90°
Metric serration	t	1.5 x 60°	1.5 x 60°	1.5 x 60°	-	-	-	-
	α	17.5°	17.5°	17.5°	17.5°	17.5°	15°	15°
	β	45°	45°	45°	45°	45°	45°	45°
Stroke per jaw	mm	4.5	5.25	6	6.5	6.5	8	8
Equalising per jaw	mm	3.4	4	5	5	5	6	6
Max. actuating force	kN	40	50	60	85	85	90	90
Max. total gripping force	kN	100	125	150	210	210	230	230
Max. speed	min-1	5000	4500	4000	3200	3200	2300	1800
Weight (without jaws)	kg	24.5	42	66	123	121.5	200	330
Moment of inertia	kg·m ²	0.15	0.4	0.92	2.75	2.7	7.12	18.1
Recommended actuating cylinder		SIN-S 100 / 125	SIN-S 125 / 150	SIN-S 125 / 150	SIN-S 150 / 175	SIN-S 150 / 175	SIN-S 150 / 175	SIN-S 150 / 175
Recommended actuating cylinder		VNK-T2 130-52	VNK-T2 170-77	VNK-T2 225-95	VNK-T2 250-110	VNK-T2 250-110	VSG 450-165	VSG 450-165

* for Zoll
** for metric

Centco4-D

INCH SERRATION

■ Jaws*

MHB-D (INCH SERRATION) Hard, reversible stepped top jaws

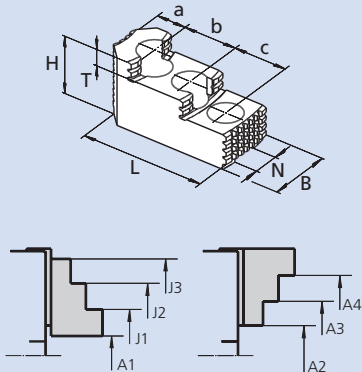

Centco4	210-52	260-72	315-92	400-112	500-115	630-165
Jaw type	MHB-D 160	MHB-D 200	MHB-D 200	MHB-D 251	MHB-D 500	MHB-D 500
Id. No.	12081638	12082038	12082038	12083038	12084548	12084548
Serration	1/16" x 90°	1/16" x 90°	1/16" x 90°	1/16" x 90°	3/32" x 90°	3/32" x 90°
B	34	40	40	45	60	60
H	39	45	45	56	75	75
L	65.2	82	82	106.2	140.8	140.8
T	10	10.5	10.5	13.5	19	19
N	14	17	17	21	25.5	25.5
a	18	19	19	26	38	38
b	16.5	23	23	30	38	38
c	16.5	23	23	30	38	38
kg / set	0.9	2.3	2.3	2.9	9.5	9.5
A1	41 - 127	52 - 161	66 - 216	69 - 263	109.5 - 320	119 - 448.5
A2	-	-	-	-	-	-
A3	90 - 173.5	102.5 - 211.5	116.5 - 265.5	160 - 355	229 - 440	239 - 573
A4	138 - 210**	177.5 - 260**	192 - 315**	245 - 400**	328 - 500**	338 - 630**
J1	87 - 172	100 - 208	114 - 263	124 - 316.5	193.5 - 403	204 - 531.5
J2	135 - 210**	174 - 260**	188 - 315**	207 - 400**	291.5 - 500**	301.5 - 630**
J3	197.5 - 210**	216 - 260**	230 - 315**	279 - 400**	389.5 - 500**	399 - 630**

MWB-D (INCH SERRATION) Soft top jaws Tall version

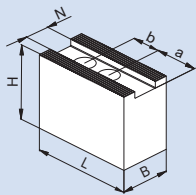

Centco4	210-52	260-72	315-92	400-112	500-115	630-165
Jaw type	MWB-D 165	MWB-D 200	MWB-D 200	MWB-D 250	MWB-D 400	MWB-D 400
Id. No.	5318607	5318837	5318837	5319680	5319831	5319831
Serration	1/16" x 90°	1/16" x 90°	1/16" x 90°	1/16" x 90°	3/32" x 90°	3/32" x 90°
B	35	40	40	50	60	60
H	60	60	60	80	90	90
L	70	90	90	120	170	170
N	14	17	17	21	25.5	25.5
a	33	43	43	62	90	90
b	16.5	22	22	28	35	35
kg / set	2.8	4.1	4.1	9.2	21.6	21.6

AWB-D (INCH SERRATION) Soft top jaws Low / pointed version

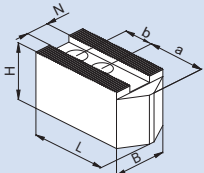

Centco4	210-52	260-72	315-92	400-112	500-115	630-165
Jaw type	AWB-D 165	AWB-D 200	AWB-D 200	AWB-D 250	AWB-D 400	AWB-D 400
Id. No.	5318608	5318838	5318838	5319681	5319834	5319834
Serration	1/16" x 90°	1/16" x 90°	1/16" x 90°	1/16" x 90°	3/32" x 90°	3/32" x 90°
B	40	40	40	50	60	60
H	40	40	40	50	60	60
L	100	110	110	120	170	170
N	14	17	17	21	25.5	25.5
a	43	53	53	70	115	115
b	22	22	22	28	35	35
kg / set	2.4	2.7	2.7	5.4	14.5	14.5

SBS-D (INCH SERRATION) Soft pie jaws

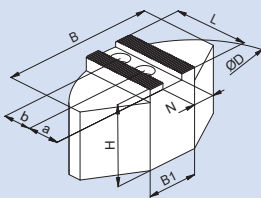

Centco4	210-52	260-72	315-92	400-112	500-115	630-165
Jaw type	SBS-D 165	SBS-D 200	SBS-D 200	SBS-D 200	SBS-D 400	SBS-D 400
Id. No.	5318610	5318839	5318839	5319684	5319832	5319832
Serration	1/16" x 90°	1/16" x 90°	1/16" x 90°	1/16" x 90°	3/32" x 90°	3/32" x 90°
B	120	140	140	180	330	330
B1	40	64	64	50	190	190
D	165	200	200	250	440	440
H	60	60	60	70	85	85
L	60	70	70	80	155	155
N	14	17	17	21	25.5	25.5
a	25	35	35	30	85	85
b	22	22	22	29	35	35
kg / set	7.1	10.3	10.3	18.3	71	71

SBA-D (INCH SERRATION) Soft pie jaws aluminum light version

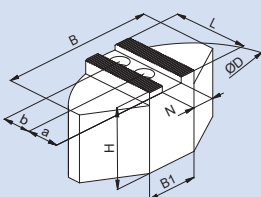

Centco4	210-52	260-72	315-92	400-112	500-115	630-165
Jaw type	SBA-D 165	SBA-D 200	SBA-D 200	SBA-D 250	SBA-D 400	SBA-D 400
Id. No.	5318609	5318840	5318840	5319685	5319833	5319833
Serration	1/16" x 90°	1/16" x 90°	1/16" x 90°	1/16" x 90°	3/32" x 90°	3/32" x 90°
B	110	120	120	160	330	330
B1	40	40	40	50	190	190
D	165	200	200	250	440	440
H	58	58	58	78	98	98
L	58	72.5	72.5	87.5	160	160
N	14	17	17	21	25.5	25.5
a	25	35	35	40	85	85
b	20	22	22	29	35	35
kg / set	2.4	3.7	3.7	7.2	32	32

* Attention: The values are calculated theoretical values only at 1 mm clamping stroke and 1 mm residual jaw stroke.
SMW-AUTOBLOK is recommending not to clamp any diameters, that are larger than the chuck O.D.
If you have any questions, please do not hesitate to contact our customer service.

** Not larger than Chuck O.D.

■ Jaws*

METRIC SERRATION

MHB-M (METRIC SERRATION) Hardened reversible top jaws

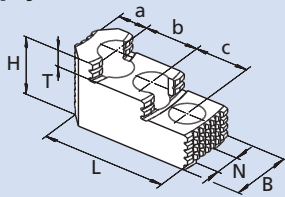

Clamping ranges

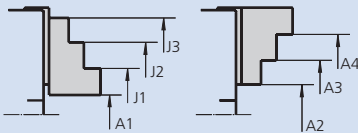

Centco4	210-52	260-72	315-92
Jaw type	MHB-M 140/4	MHB-M 140/4	MHB-M 140/4
Id. No.	12082129	12082129	12082129
Serration	1.5 x 60°	1.5 x 60°	1.5 x 60°
B	40	40	40
H	45	45	45
L	86	86	86
T	10.5	10.5	10.5
N	14	14	14
a	19	19	19
b	25	25	25
c	25	25	25
kg / set	2.4	2.4	2.4
A1	23.5 - 61.5	55 - 112	60.5 - 167
A2	-	-	-
A3	78.5 - 116	109.5 - 166	115 - 220
A4	153.5 - 191	185 - 242	191 - 296
J1	79 - 113.5	108 - 163	113 - 218
J2	150.5 - 187.5	181.5 - 238	186.5 - 293
J3	196 - 210**	227 - 260**	232.5 - 315**

WBJ-M (METRIC SERRATION) Soft top jaws

Tall version

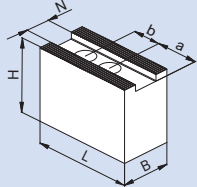

Centco4	210-52	260-72	315-92
Jaw type	WBJ-M 1403/4	WBJ-M 1403/4	WBJ-M 1403/4
Id. No.	5311479	5311479	5311479
Serration	1.5 x 60°	1.5 x 60°	1.5 x 60°
B	40	40	40
H	60	60	60
L	90	90	90
N	14	14	14
a	45	45	45
b	25	25	25
kg / set	3.6	3.6	3.6

AWB-M (METRIC SERRATION) Soft top jaws

Low / pointed version

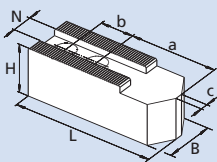

Centco4	210-52	260-72	315-92
Jaw type	AWB-M 1401/4	AWB-M 1401/4	AWB-M 1401/4
Id. No.	5311476	5311476	5311476
Serration	1.5 x 60°	1.5 x 60°	1.5 x 60°
B	35	35	35
H	40	40	40
L	102	102	102
N	14	14	14
a	57	57	57
b	25	25	25
c	4	4	4
kg / set	3.5	3.5	3.5

SBJ-M (METRIC SERRATION) Soft pie jaws

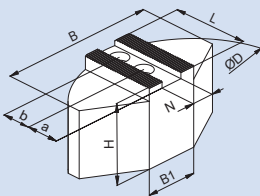

Centco4	210-52	260-72	315-92
Jaw type	SBJ-M 200/4	SBJ-M 200/4	SBJ-M 200/4
Id. No.	5311478	5311478	5311478
Serration	1.5 x 60°	1.5 x 60°	1.5 x 60°
B	140	140	140
B1	70	70	70
D	200	200	200
H	60	60	60
L	70	70	70
N	14	14	14
a	30	30	30
b	25	25	25
kg / set	12	12	12

SBJ-MA (METRIC SERRATION) Soft pie jaws aluminum

Light version

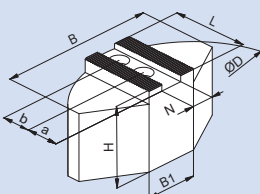

Centco4	210-52	260-72	315-92
Jaw type	SBJ-MA 200/4	SBJ-MA 200/4	SBJ-MA 200/4
Id. No.	5311477	5311477	5311477
Serration	1.5 x 60°	1.5 x 60°	1.5 x 60°
B	140	140	140
B1	50	50	50
D	200	200	200
H	58	58	58
L	75	75	75
N	14	14	14
a	35	35	35
b	25	25	25
kg / set	4.1	4.1	4.1

* Attention: The values are calculated theoretical values only at 1 mm clamping stroke and 1 mm residual jaw stroke.
SMW-AUTOBLOK is recommending not to clamp any diameters, that are larger than the chuck O.D.

If you have any questions, please do not hesitate to contact our customer service.

** Not larger than Chuck O.D.

GG-D (INCH SERRATION) Hard roughing jaws

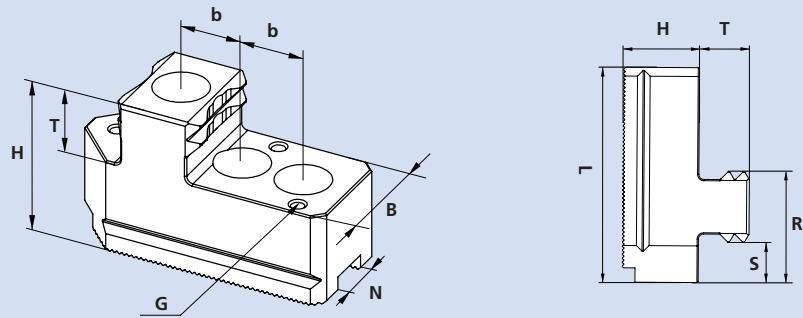

Type	Id. No.	External clamping*	Internal clamping*	B	H	L	R	S	T	G	N	b	Serration	kg / Set	SMW-AUTOBLOK Chuck
GG-D 210	5325558	48-205	104-210	35	50	85	44	16	20	M5	14	20	1/16"x90°	2.252	Centco4 D210
GG-D 260	5325560	49-256	128-260	36	55	100	52	11	20	M5	17	25	1/16"x90°	3.364	Centco4 D260
GG-D 315	5325562	50-309	146-315	40	55	110	65	17	20	M8	17	25	1/16"x90°	4.184	Centco4 D315
GG-D 400	5325564	72-394	171-400	50	60	130	64	13	22	M8	21	32,5	1/16"x90°	6.8524	Centco4 D400
GG-D 500	5325565	127-495	242-500	60	60	150	73	14,5	22	M8	25.5	40	3/32"	9.04	Centco4 D500
GG-D 630	5325566	105-630	242-630	60	60	180	83	13	22	M8	25.5	50	3/32"	11.492	Centco4 D630

GG-M (METRIC SERRATION) Hard roughing jaws

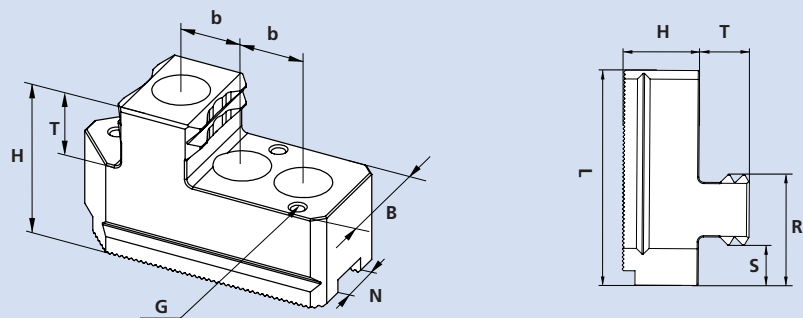

Type	Id. No.	External clamping	Internal clamping	B	H	L	R	S	T	G	N	b	Serration	kg / Set	SMW-AUTOBLOK Chuck
GG-M 210	5325559	46-201	113-210	35	50	85	49	15	20	M5	14	21,5	1.5x60°	2.268	Centco4 M210
GG-M 260	5325561	65-258	141-260	36	55	100	51	13,5	20	M5	14	23	1.5x60°	3.224	Centco4 M260
GG-M 315	5325563	51-308	147-315	40	55	110	65	17	20	M8	14	25	1.5x60°	4.224	Centco4 M315

* Attention: The values are calculated theoretical values. SMW-AUTOBLOK is recommending not to clamp any diameters, that are larger than the chuck O.D.
If you have any questions, please do not hesitate to contact our customer service.

Centco4

INCH / METRIC
SERRATION

- T-Nuts
- Covers for through-hole

NST T-nuts suitable for Centco4-D

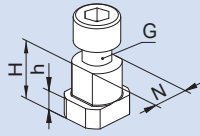

Centco4	210-52	260-72	315-92	400-112	500-155	630-165
T-nut type	NST14	NST17	NST17	NST21	NST25	NST25
Id. No.	163134	016021	016021	014788	014812	014812
	N 14	17	17	21	25.5	25.5
	H 20	23	23	27	29	29
	h 7.5	9	9	10	11	11
	G					
Cyl.-screw ISO 4762-12.9	M10 x 25	M12 x 30	M12 x 30	M16 x 35	M20 x 40	M20 x 40
Torque Md max. (Nm)	40	60	60	150	200	200

NST T-nuts suitable for Centco4-M

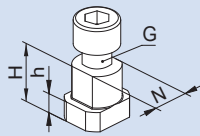

Centco4	210-52	260-72	315-92
T-nut type	NST17/14	NST17/14	NST17/14
Id. No.	036976	036976	036976
	N 14	14	14
	H 20.5	20.5	20.5
	h -	-	-
	G		
Cyl.-screw ISO 4762-12.9	M12 x 25	M12 x 25	M12 x 25
Torque Md max. (Nm)	60	60	60

cover for through-hole



Centco4	210-52	260-72	315-92	400-112	500-155	630-165
Id. No.	163135	163136	163137	163138	163584	163585

**Important for maintenance and safe operation,
to be ordered with the chuck**

Grease K67

Special grease for
manual and power chucks



Cartridge 14 Oz. (DIN 1284)
Grease content 500 g
Id. No. 10731223

Can 1000 g
Id. No. 10731224



- High adhesion
- High resistance against coolant
- High load bearing capacity
- Low friction coefficient
- Avoids tribocorrosion

Grease gun

Grease gun (DIN 1283) for
cartridges 14 Oz. (DIN 1284)

- Also refillable from grease can 1000 g

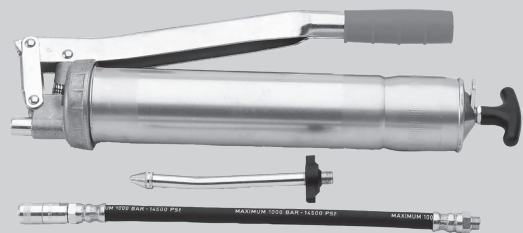

Lubrication set Id. No. 083726

Supply range

- Grease gun
- 1 Adapter flexible for high pressure grease nipple
- 1 Adapter for cone grease nipple

Subject to technical changes.
For more detailed information please ask our customer service.

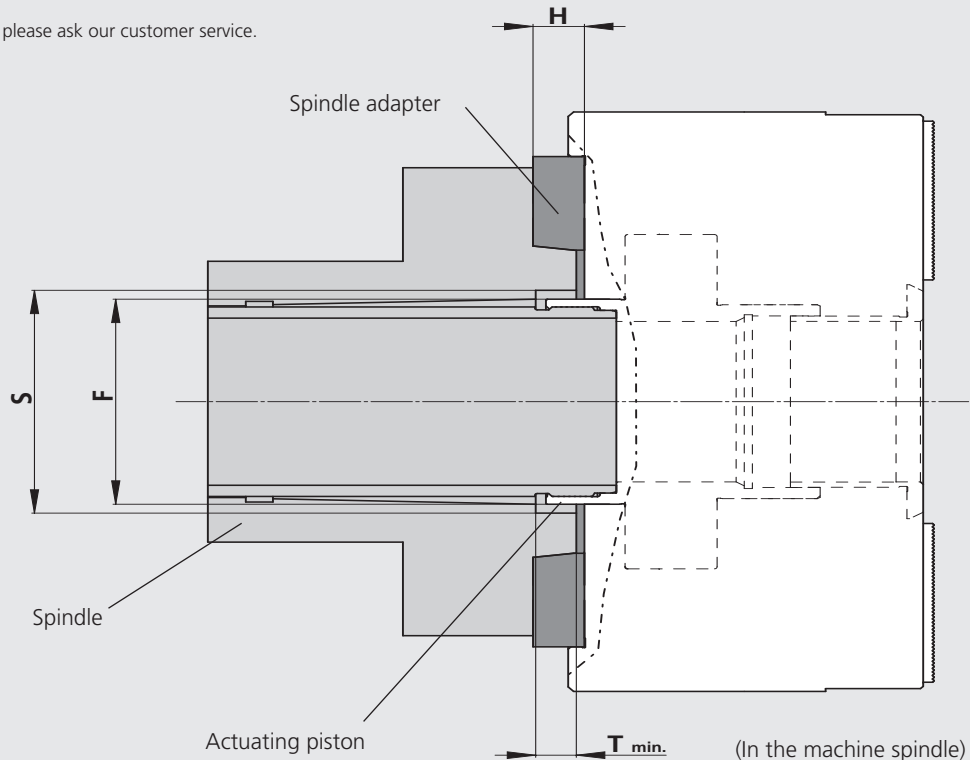

Base chuck type Centco4 D / M	Spindle mounting	Actuating piston dia. F [mm]	Clearance - dia. S [mm]	Clearance - depth T min. [mm]*	Id. No. Spindle adapter	Spindle adapter height H [mm]	Order review ASA	
							Id. No. cpl. Chuck inch serration D + Spindle adapter	Id. No. cpl. Chuck metric serration M + Spindle adapter
210-52-Z170	A06	68	> 68	14	24162000	17	163842	163844
			< 68	-	24162110	40	163843	163845
260-72-Z220	A06	92	< 92	-	24162532	50	163874	163877
	A08	92	> 92	17	24182500	19	163875	163878
< 92			-	24182520	43	163876	163879	
315-92-Z300	A08	115	> 115	10	24183100	30	163880	163885
			< 115	-	24184000	40	163881	163886
	A11	115	> 115	20	24113100	21	163882	163887
			> 115	11	24113110	30	163883	163888
< 115	-	2704390	44	163884	163889			
400-112-Z300	A11	142	< 142	-	2704390	44	163890	-
400-112-Z380	A11	142	> 142	2	24115000	40	163891	-
			< 142	-	2704391	44	163892	-
	A15	142	> 142	23	24125000	23	163893	-
			< 142	-	2704392	47	163894	-
500-155-Z380	A11	178	> 178	8	24115000	40	163895	-
			< 178	-	2704606	50	163896	-
	A15	178	> 178	26.5	24125000	23	163897	-
			< 178	-	273765	50	163898	-
630-165-Z380	A11	188	> 188	8	24115000	40	163899	-
			< 188	-	2704606	50	163900	-
	A15	188	> 188	26.5	24125000	23	163901	-
			< 188	-	273765	55	163902	-

* to clear the axial stroke of the actuating piston (see on page „technical details piston stroke“ K)

■ Ordering review

Ordering review Centco4-D (inch serration)

Centco4-D

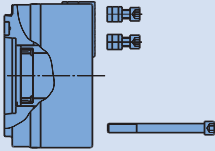

Supply range:

- Chuck + mounting bolts
- 8 pieces T-nuts with bolts

Spindle mounting / Flange height	Size					
	Centco4-D 210-52	Centco4-D 260-72	Centco4-D 315-92	Centco4-D 400-112	Centco4-D 500-155	Centco4-D 630-165
Centering rim small	-	-	-	Z 300 163175	-	-
Centering rim large	Z 170 163120	Z 220 162780	Z 300 163140	Z 380 163160	Z 380 163580	Z 380 163770
A 06 (17**)	163842	-	-	-	-	-
A 06 (40**)	163843	-	-	-	-	-
A 06 (50**)	-	163874	-	-	-	-
A 08 (19**)	-	163875	-	-	-	-
A 08 (30**)	-	-	163880	-	-	-
A 08 (40**)	-	-	163881	-	-	-
A 08 (43**)	-	163876	-	-	-	-
A 11 (21**)	-	-	163882	-	-	-
A 11 (30**)	-	-	163883	-	-	-
A 11 (40**)	-	-	-	163891*	163895	163899
A 11 (44**)	-	-	163884	163890	-	-
A 11 (44**)	-	-	-	163892*	-	-
A 11 (50**)	-	-	-	-	163896	163900
A 15 (23**)	-	-	-	163893*	163897	163901
A 15 (47**)	-	-	-	163894*	-	-
A 15 (50**)	-	-	-	-	163898	163902

Ordering review Centco4-M (metric serration)

Centco4-M

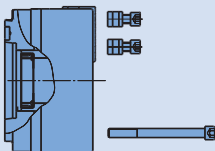

Supply range:

- Chuck + mounting bolts
- 8 pieces T-nuts with bolts

Spindle mounting / Flange height	Size		
	Centco4-M 210-52	Centco4-M 260-72	Centco4-M 315-92
Centering rim small	-	-	-
Centering rim large	Z 170 163795	Z 220 162795	Z 300 163797
A 06 (17**)	163844	-	-
A 06 (40**)	163845	-	-
A 06 (50**)	-	163877	-
A 08 (19**)	-	163878	-
A 08 (30**)	-	-	163885
A 08 (40**)	-	-	163886
A 08 (43**)	-	163879	-
A 11 (21**)	-	-	163887
A 11 (30**)	-	-	163888
A 11 (44**)	-	-	163889

* With base chuck Centco4-400-112-Z380

** Refers to height of spindle flange see page „spindle adapters“