

BB-D

INCH
SERRATION

BB-M

METRIC
SERRATION

High precision power chuck Ø 140 - 435 mm

- EXTRA large through-hole
- 3 jaws



Application/customer benefits

- For open center or partial open center clamping
- For machines with very large spindle bore

BB-D: Master jaws with INCH SERRATION (1/16" x 90°)

BB-M: Master jaws with METRIC SERRATION (1.5 mm x 60°)
(Suitable for Japanese chucks top jaws)

Technical features

- EXTRA large through-hole
- Gripping force transmission via wedge hook
- Case hardened body to assure greatest precision and long chuck life

Standard equipment

- 3-jaw chuck
- 1 set T-nuts with bolts
- 1 set soft top jaws
- Mounting bolts

Ordering example

- 3-jaw chuck BB-D 175 / A6
- or
- 3-jaw chuck BB-M 250 / Z220

Actual gripping force diagrams

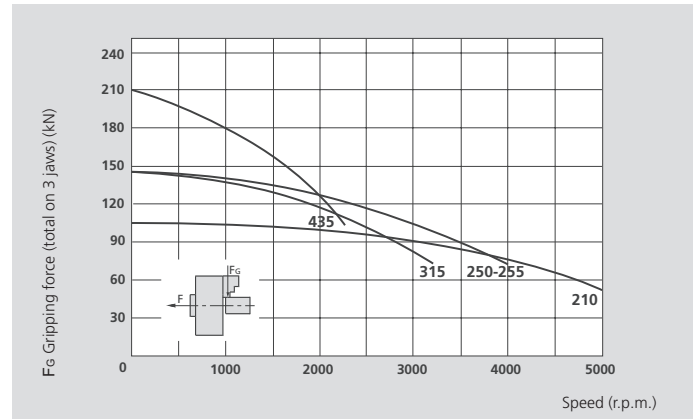
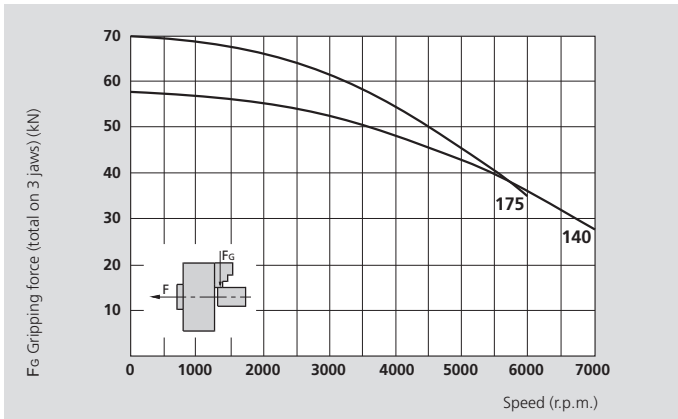

The data in the diagrams refer to 3-jaw chucks, newly maintained according to their service manuals using SMW-AUTOBLOK K67 grease. The static and dynamic gripping forces have been measured using standard soft top jaws, placed in a position not exceeding the outer diameter of the chuck.

⚠ Safety advice / danger of damage:

When using taller / heavier jaws and / or clamping on a bigger diameter reduce draw pull / rotating speed accordingly.

Technical data

SMW-AUTOBLOK Type		BB-D 140 BB-M 140	BB-D 175 BB-M 175	BB-D 210 BB-M 210	BB-D 250 BB-M 250	BB-D 255 BB-M 255	BB-D 315 BB-M 315	BB-D 435 BB-M 435
Number of jaws		3	3	3	3	3	3	3
Through-hole	mm	39	56	66	78	82	122	167
Radial jaw stroke	mm	3.2	3.2	4	5	5	5	6,5
Axial piston stroke	mm	15	15	19	24	24	24	31
Max. draw pull*	kN	22	25	38	50	50	50	70
Max. gripping force*	kN	58	70	108	145	145	145	210
Max. speed	r.p.m.	7000	6000	5000	4000	4000	3200	2250
Weight (without top jaws)	kg	6	11.5	19.5	30	33	44	122
Moment of inertia	kg·m ²	0.016	0.05	0.12	0.27	0.32	0.62	3,5
Recommended actuating cylinders without hole		SIN-S 85/100	SIN-S 100	SIN-S 100/25	SIN-S 125/150	SIN-S 125/150	SIN-S 125/150	SIN-S 150/200
Recommended actuating cylinders with hole		VNK-T2 70-37	VNK-T2 130-52	VNK-T2 150-67	VNK-T2 170-77	VNK-T2 176-82	VNK-T2 320-127	VNK-T2 450-165
Id. No. BB-D 3 jaws (Center mounting)		77150714	77150917	77150921	77150725	77150726	77150731	77150743
Id. No. BB-M 3 jaws (Center mounting)		77150814	77151117	77151121	77151025	77151026	77150831	77150843

* For internal clamping reduce the draw pull by 30%.



SMW-AUTOBLOK
472

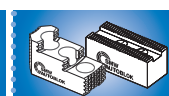

SMW-AUTOBLOK
474



SMW-AUTOBLOK
331

High precision power chuck Ø 140 - 435 mm

- EXTRA large through-hole
- 3 jaws

BB-D

INCH
SERRATION

BB-M

METRIC
SERRATION

2

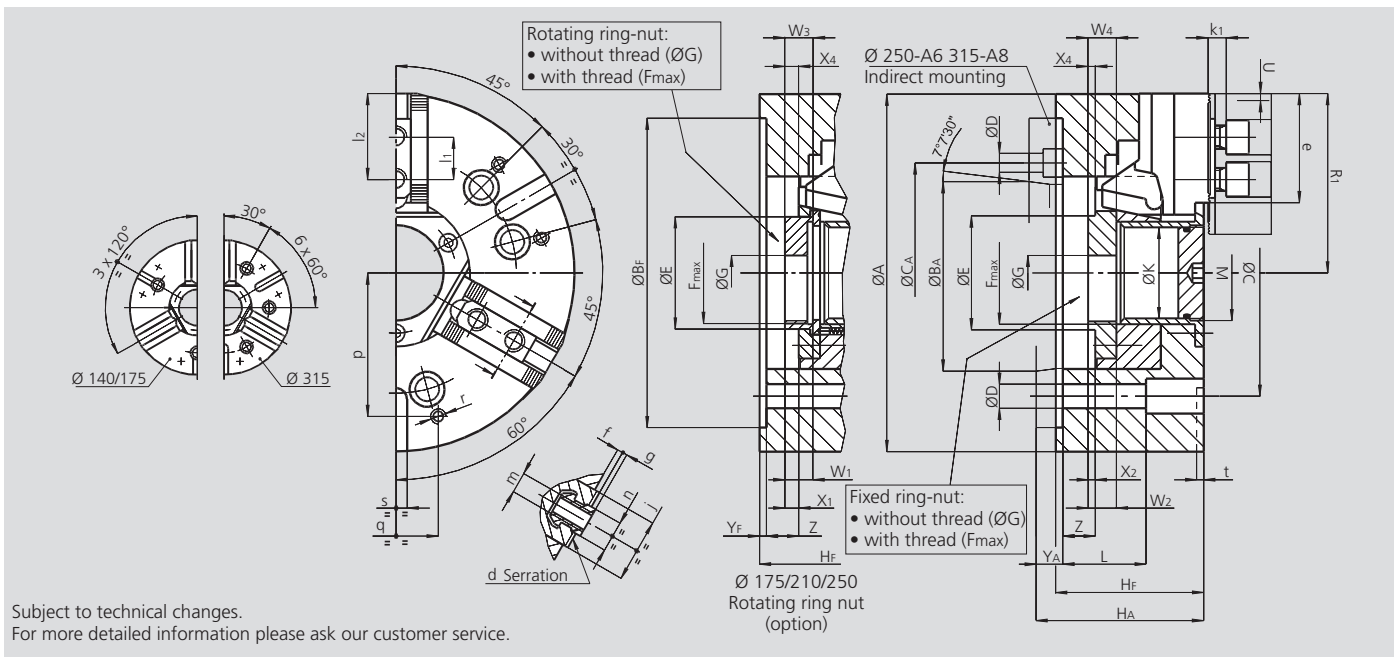

Subject to technical changes.
For more detailed information please ask our customer service.

SMW-AUTOBLOK Type			BB-D 140 BB-M 140		BB-D 175 BB-M 175		BB-D 210 BB-M 210		BB-D 250 BB-M 250			BB-D 255 BB-M 255			BB-D 315 BB-M 315			BB-D 435 BB-M 435		
Mounting			Z130	A5	Z160	A6	Z170	A6	Z220	A6	A8	Z220	A6	A8	Z300	A8	A11	Z380	A11	A15
	A	mm	140		175		210		254			255			315			435		
	BF/BA H6	mm	130	82.563	160	106.375	170	106.375	220	106.375	139.719	220	106.375	139.719	300	139.719	196.869	380	196.869	285.775
	C	mm	104.8		133.4		133.4		171.4	-	171.4	171.4	-	171.4	235	-	235	330.2	-	330.2
	CA	mm	-	-	-	-	-	-	133.4	-	-	133.4	-	-	-	171.4	-	-	235	-
	D	mm	11.5		13.5		13.5		13.5	17	17	13.5	17	17	17	21	26	27	26	
	E	mm	53		71		78		92			95			143			191		
	Fstd	mm	M45 x 1.5		M62 x 1.5		M72 x 1.5		M85 x 2			M90 x 2			M135 x 2			M180 x 3		
	G	mm	16		20		20		25			20			70			30		
	Hf/HA	mm	67	77	82	94	92	104	105	124	119	105	124	119	118	143	134	128	162	146
	K	mm	39		56		66		78			82			122			167		
	L	mm	46		54		66		79			79			72			89		
	M	mm	M42 x 1.5		M58 x 1.5		M68 x 2		M80 x 2			M84 x 2			M125 x 2			-		
Chuck open	R1	mm	70		89		106		128.5			130.5			157.5			220		
Jaw stroke	U	mm	3.2		3.2		4		5			5			5			6.5		
	(1) W1/W2	mm	- / 14		18 / 16		20 / 18		20 / 20			20 / 20			- / 23			- / 23		
	(2) W3/W4	mm	- / 14		28 / 35		30 / 35		33 / 38			33 / 38			- / 23			- / 35		
BB-D	X1/X2	mm	- / 6		11 / 5		12 / 5		11 / 6			9 / 4			- / 5			- / 5		
BB-M	X1/X2 (X4)	mm	- / 6 (6)		11 / 5 (22)		12 / 5 (22)		11 / 11 (23)			9 / 4 (23)			- / 5 (5)			- / 5		
	Yf/YA	mm	5	15	5	17	5	17	5	24	19	5	24	19	5	30	21	6	40	23
Max. / min.	Z	mm	15 / 0		15 / 0		19 / 0		24 / 0			24 / 0			24 / 0			31 / 0		
BB-D	serration	d	1/16" x 90°		1/16" x 90°		1/16" x 90°		1/16" x 90°			1/16" x 90°			1/16" x 90°			3/32" x 90°		
BB-M	serration	d	1.5 x 60°		1.5 x 60°		1.5 x 60°		1.5 x 60°			1.5 x 60°			1.5 x 60°			1.5 x 60°		
	e	mm	39		49.5		59		73			72.5			77.5			116.5		
	f	mm	2		3		3		4			4			4			5		
	g	mm	2.5		2.5		2.5		3.5			3.5			3.5			3.5		
	j	mm	30		33		38		45			45			45			62		
	k1	mm	10		10		11		12			12			12			16		
BB-D	l1	mm	16		16.5		23		30			30			30			31 / 106		
BB-M	l1	mm	16		20		25		30			30			30			31 / 106		
Max. / min.	l2	mm	32 / 23		41 / 24		49 / 33		57 / 43			57 / 43			62 / 43			121 / 53		
BB-D	m	mm	M8		M10		M12		M16			M16			M16			M20		
BB-D	n h8	mm	12		14		17		21			21			21			25.5		
BB-M	m	mm	M8		M10		M12		M12			M12			M16			M20		
BB-M	n h8	mm	12		12		14		16			16			21			22		
	p	mm	52		65		80		102			102			100			150		
	q	mm	30		36		45		60			60			60			80		
	r	mm	M6		M8		M8		M10			M10			M10			M12		
	s H12	mm	12		16		16		16			16			20			20		
	t	mm	5		5		5		5			5			5			5		

(1) Rotating ring-nut with thread
Fixed ring-nut with thread

W₁=BBD-BBM
W₂=BBD-BBM

(2) Blank rotating ring-nut without thread
Fixed ring-nut blank without thread

W₃ = BBD-BBM
W₄ = BBD-BBM