

BH-D

Big diameters

INCH
SERRATION

High precision power chuck Ø 500 - 800 mm

- Large through-hole
- 3 jaws

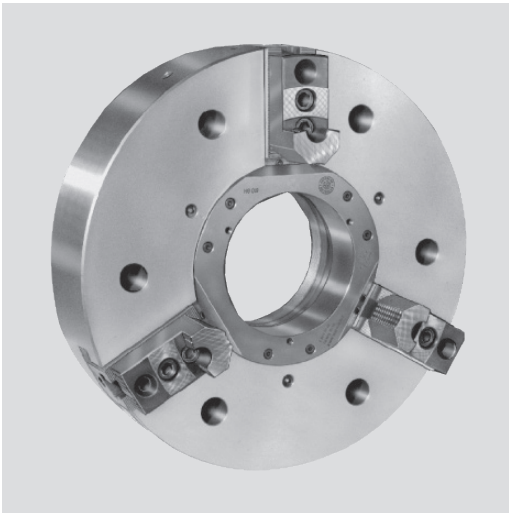

Application/customer benefits

- For open center or partial open center clamping
- Large through-hole

BH-D: Master jaws with INCH SERRATION 3/32" x 90°

Technical features

- Gripping force transmission via wedge hook

Standard equipment

- 3-jaw chuck
- 1 set T-nuts with bolts
- 1 set soft top jaws
- Blank ring-nut
- Mounting bolts

Ordering example

- 3-jaw chuck BH-D 500 / A15
- or
- 3-jaw chuck BH-D 800 / Z520

Actual gripping force diagram

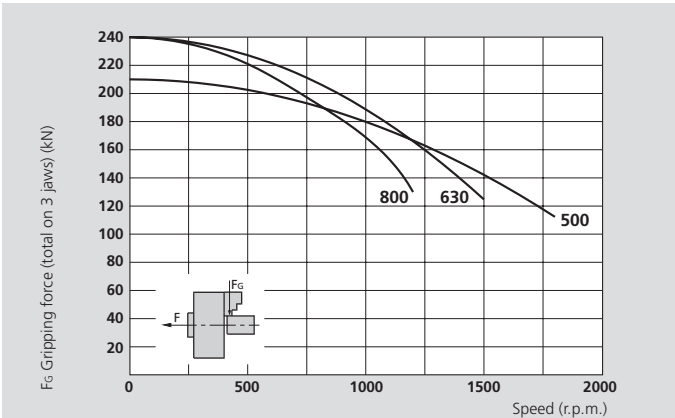

The data in the diagram refers to 3-jaw chucks, newly maintained according to their service manuals using SMW-AUTOBLOK K67 grease. The static and dynamic gripping forces have been measured using standard soft top jaws, placed in a position not exceeding the outer diameter of the chuck.

△ Safety advice / danger of damage:

When using taller / heavier jaws and / or clamping on a bigger diameter reduce draw pull / rotating speed accordingly.

Technical data

SMW-AUTOBLOK Type		BH-D 500	BH-D 630	BH-D 800
Number of jaws		3	3	3
Through-hole	mm	180	230	230
Radial jaw stroke	mm	6.5	9	9
Axial piston stroke	mm	31	34	34
Max. draw pull*	kN	70	100	100
Max. gripping force*	kN	210	240	240
Max. speed	r.p.m.	1800	1500	1200
Weight (without top jaws)	kg	140	280	530
Moment of inertia	kg·m ²	5	16	47
Recommended actuating cylinders		SIN-S 150 / 200 VSG 450-165	SIN-S 150 / 200 VSG 550-205	SIN-S 150 / 200 VSG 550-205
Id. No. BH-D 3 jaws (Center mounting)		77152750	77152763	77152780

* For internal clamping reduce the draw pull by 30%.



SMW-AUTOBLOK
472

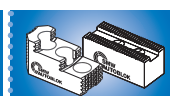

SMW-AUTOBLOK
474



SMW-AUTOBLOK
331

High precision power chuck Ø 500 - 800 mm

BH-D

Big diameters
INCH
SERRATION

- Large through-hole
- 3 jaws

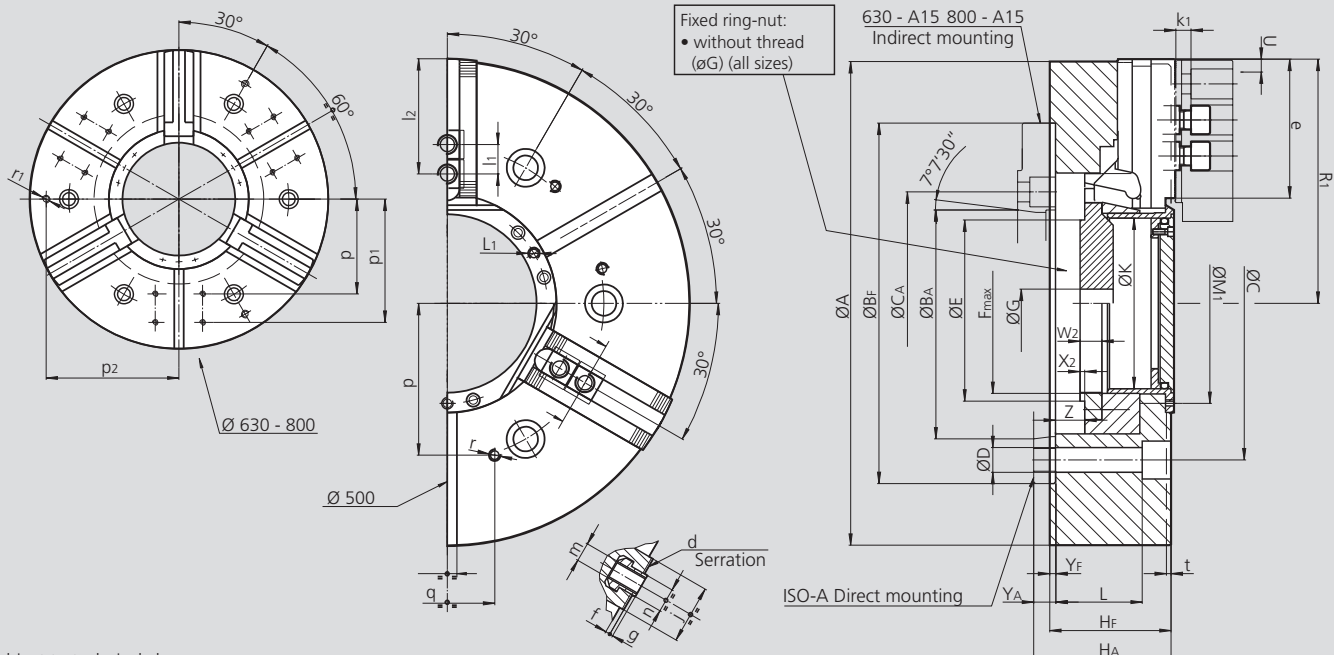

Subject to technical changes.
For more detailed information please ask our customer service.

SMW-AUTOBLOK Type			BH-D 500		BH-D 630			BH-D 800		
Mounting			Z380	A15	Z520	A15	A20	Z520	A15	A20
	A	mm	510		630			800		
	Bf/BA H6	mm	380	285.775	520	285.775	412.775	520	285.775	412.775
	C	mm	330.2		463.6	-	463.6	463.6	-	463.6
	CA	mm	-	-	-	330.2	-	-	330.2	-
	D	mm	26		26			26		
	E	mm	206		260			260		
	Fmax	mm	M190 x 3 (*)		M250 x 3 (*)			M250 x 3 (*)		
	G	mm	30		30			30		
	Hf/HA	mm	128	145	150	184	169	150	184	169
	K	mm	180		230			230		
	L	mm	91		99			99		
	L1	mm	M8 / 9		M8 / 16			M8 / 16		
	M1	mm	211		270			270		
Chuck open	R1	mm	257.5		314			399		
Jaw stroke	U	mm	6.5		9			9		
	W2	mm	23		23			23		
	X2	mm	5		5			5		
	Yf/YA	mm	6	23	6	40	25	6	40	25
Max. / min.	Z	mm	31 / 0		34 / 0			34 / 0		
BH-D serration	d	inch	3/32" x 90°		3/32" x 90°			3/32" x 90°		
	e	mm	146.5		152			237		
	f	mm	5		10			10		
	g	mm	3.5		3.5			3.5		
	j	mm	62		62			62		
	k1	mm	16		16			16		
	l1	mm	38		38			38		
Max. / min.	l2	mm	121 / 53		127 / 53			212 / 53		
	m	mm	M20		M20			M20		
	n h8	mm	25.5		25.5			25.5		
	p	mm	160		200			200		
	p1	mm	-		260			260		
	p2	mm	-		280			280		
	q	mm	100		100			100		
	r	mm	M12 / 22		M12 / 22			M12 / 22		
	r1	mm	-		M16 / 28			M16 / 28		
	s H12	mm	20		20			20		
	t	mm	5		5			5		

* Max. possible thread on blank ring-nut.