

BP-C

TONGUE & GROOVE

High precision power chuck Ø 220 - 320 mm

- Large through-hole
- 3 jaws
- proofline® chucks = fully sealed - low maintenance

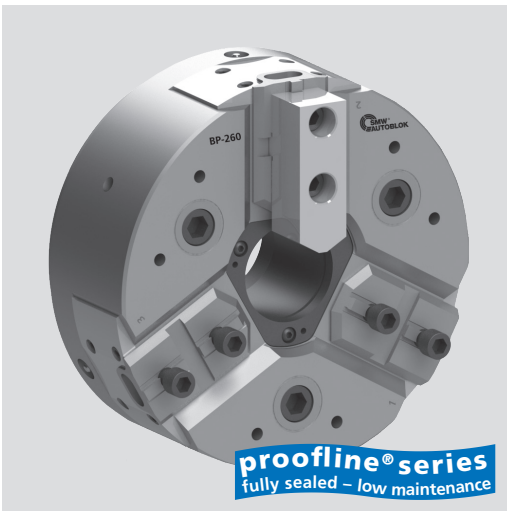

Application/customer benefits

- General use on standard lathes due to the through-hole, but with advantage of minimum maintenance and use also in extreme environments
- Longer life at high precision due to less wear
- Fully sealed, ideal for dry machining of castings and forgings or if high pressure coolant is used

BP-C: TONGUE & GROOVE master jaws (American Standard)

Technical features

- Constant gripping force with permanent grease lubrication
- Large through-hole compatible with the standard machines
- 3-jaw version available in all diameters
- Proofline chucks = fully sealed - low maintenance

Standard equipment

3-jaw chuck
Mounting bolts

Ordering example

3-jaw chuck BP-C 220 / Z170

Actual gripping force diagram

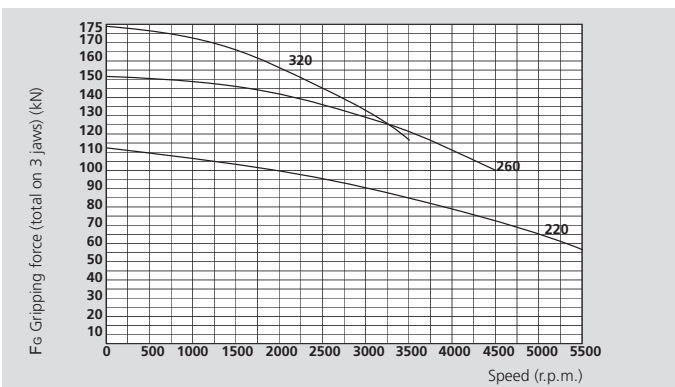

The data in the diagram refers to 3-jaw chucks, newly maintained according to their service manuals using SMW-AUTOBLOK K67 grease. The static and dynamic gripping forces have been measured using standard soft top jaws, placed in a position not exceeding the outer diameter of the chuck.

⚠ Safety advice / danger of damage:

When using taller / heavier jaws and / or clamping on a bigger diameter reduce draw pull / rotating speed accordingly.

Technical data

SMW-AUTOBLOK Type		BP-C 220	BP-C 260	BP-C 320
Number of jaws		3	3	3
Through-hole	mm	52	66	95
Radial jaw stroke	mm	4	5	5
Axial piston stroke	mm	16	19	19
Max. actuation force*	kN	44	60	68
Max. gripping force*	kN	110	150	175
Max. speed	r.p.m.	5500	4500	3500
Weight (without top jaws)	kg	22	35	59
Moment of inertia	kg·m ²	0.14	0.34	0.85
Recommended actuating cylinders without hole		SIN-S 100 / 125	SIN-S 125 / 150	SIN-S 125 / 150
Recommended actuating cylinders with hole		VNK-T2 130-52	VNK-T2 150-67	VNK-T2 225-95
Id. No. BP-C 3 jaws (Center mounting)		77189322	77189326	77189332

* For internal clamping reduce the draw pull by 30%.

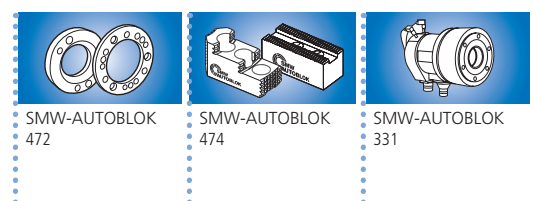

High precision power chuck Ø 220 - 320 mm

BP-C

- Large through-hole
- 3 jaws
- proofline® chucks = fully sealed - low maintenance

TONGUE & GROOVE

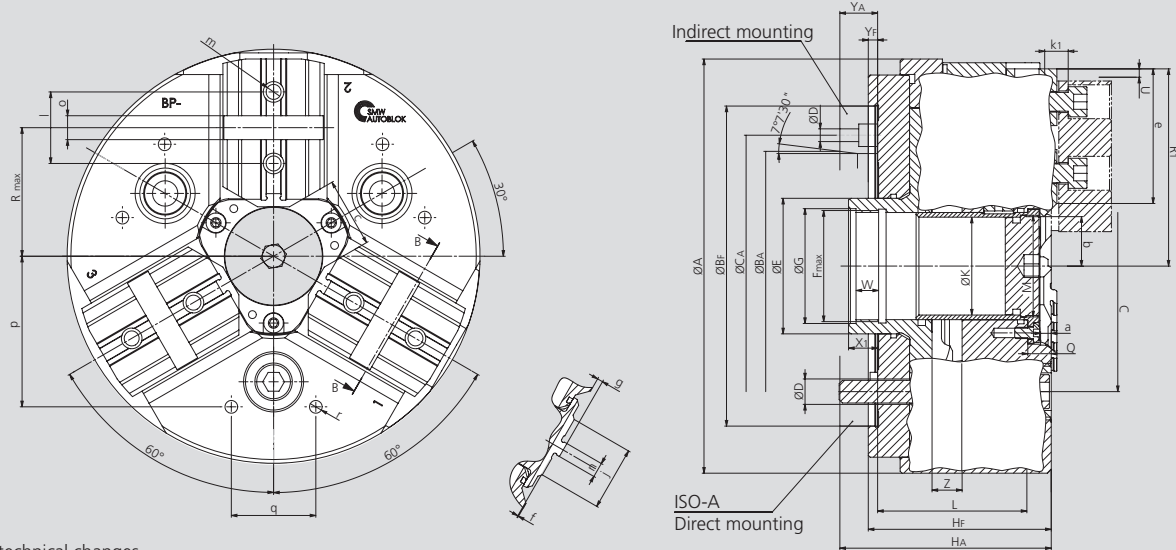

Subject to technical changes.
For more detailed information please ask our customer service.

SMW-AUTOBLOK Type			BP-C 220		BP-C 260			BP-C 320		
Mounting			Z170	A6	Z220	A6	A8	Z300	A8	A11
	A	mm	220		262			320		
	BF/BA H6	mm	170	106.375	220	106.375	139.719	300	139.719	196.869
	C	mm	133.4		171.4			235		
	CA	mm	-	-	-	133.4	-	-	171.4	-
	D	mm	13.5		17	13.5	17	21		
	E	mm	72		88			115		
	Fmax	mm	M60 x 1.5		M75 x 2			M102 x 2		
	G	mm	61		76			102.5		
	HF/HA	mm	97.5	109.5	114	149	128	114	149	130
	K	mm	52		66			95		
	L	mm	79.5		92			88		
	M	mm	M54 x 1.5		M68 x 2			M98 x 2		
	Q	mm	12.5		16.5			16.5		
Chuck open	R1	mm	109		131			159		
Max.	R	mm	72.5		89			115		
Jaw stroke	U	mm	4.3		5			5		
	W	mm	12		14			16.5		
	X1	mm	15.5		22			25		
	YF/YA	mm	5	17	5	40	19	5	40	21
Max. / min.	Z	mm	16 / 0		19 / 0			19 / 0		
Min.	a	mm	5.7		9.7			9.7		
Min.	b	mm	26.5		36			48		
	c	mm	37		52			70		
	e	mm	74.5		82			98		
	f	mm	0		3			4		
	g	mm	3		0			-1		
	j	mm	34		46			58		
	k1	mm	9		13.5			15.5		
	l	mm	38		44.4			54		
	m	mm	M10		M12			M16		
	n h7	mm	7.94		7.94			12.7		
	o H7	mm	12.68		12.68			19.03		
	p	mm	80		102			100		
	q	mm	45		60			60		
	r	mm	M8		M10			M10		