

BP-D

INCH
SERRATION

BP-M

METRIC
SERRATION

High precision power chuck Ø 220 - 320 mm

- Large through-hole
- 3 jaws
- proofline® chucks = fully sealed - low maintenance

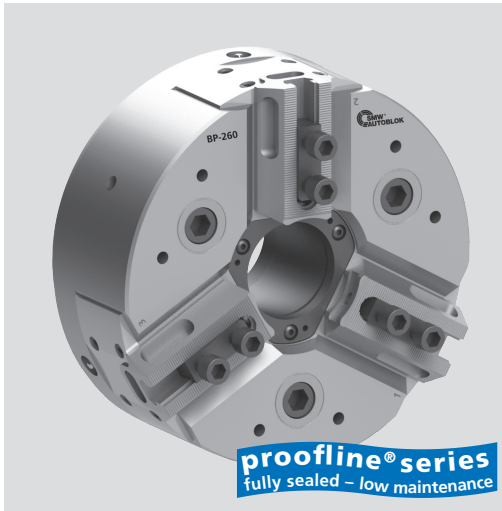

Application/customer benefits

- General use on standard lathes due to the through-hole, but with advantage of minimum maintenance and use also in extreme environments
- Longer life at high precision due to less wear
- Fully sealed, ideal for dry machining of castings and forgings or if high pressure coolant is used

BP-D: Master jaws with INCH SERRATION (1/16" x 90°)

BP-M: Master jaws with METRIC SERRATION (1.5 mm x 60°)
(suitable for japanese jaws)

Technical features

- Constant gripping force with permanent grease lubrication
- Large through-hole compatible with the standard machines
- Chuck body and internal parts case hardened
- **Proofline® chucks** = fully sealed - low maintenance

Standard equipment

3-jaw chuck
1 set T-nuts and bolts
1 set soft top jaws
Mounting bolts

Ordering example

3-jaw chuck BP-D 220 / Z170
or
3-jaw chuck BP-M 220 / A6

Actual gripping force diagram

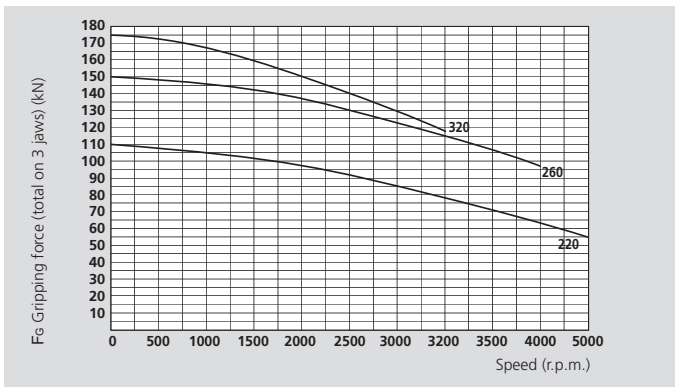

The data in the diagram refers to 3-jaw chucks, newly maintained according to their service manuals using SMW-AUTOBLOK K67 grease. The static and dynamic gripping forces have been measured using standard soft top jaws, placed in a position not exceeding the outer diameter of the chuck.

⚠ Safety advice / danger of damage:

When using taller / heavier jaws and / or clamping on a bigger diameter reduce draw pull / rotating speed accordingly.

Technical data

SMW-AUTOBLOK Type		BP-D 220 BP-M 220	BP-D 260 BP-M 260	BP-D 320 BP-M 320
Number of jaws		3	3	3
Through-hole	mm	52	66	95
Radial jaw stroke	mm	4	5	5
Axial piston stroke	mm	16	19	19
Max. actuating force*	kN	44	60	68
Max. gripping force*	kN	110	150	175
Max. speed	r.p.m.	5000	4000	3200
Weight (without top jaws)	kg	23	36	60
Moment of inertia	kg-m ²	0.14	0.34	0.85
Recommended actuating cylinders without hole		SIN-S 100 / 125	SIN-S 125 / 150	SIN-S 125 / 150
Recommended actuating cylinders with hole		VNK-T2 130-52	VNK-T2 150-67	VNK-T2 225-95
Id. No. BP-D 3 jaws (Center mounting)		77185122	77185126	77185132
Id. No. BP-M 3 jaws (Center mounting)		77185222	77185226	77185232

* For internal clamping reduce the draw pull by 30%.



SMW-AUTOBLOK
472

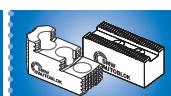

SMW-AUTOBLOK
474



SMW-AUTOBLOK
331

High precision power chuck Ø 220 - 320 mm

BP-D

BP-M

- Large through-hole
- 3 jaws
- proofline® chucks = fully sealed - low maintenance

INCH
SERRATION

METRIC
SERRATION

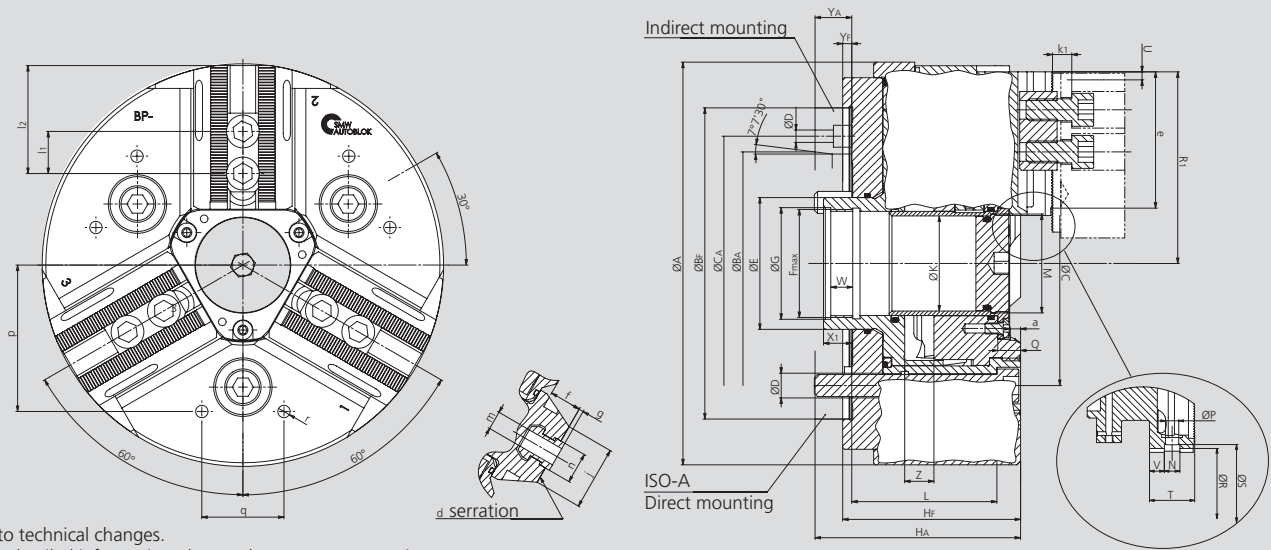

Subject to technical changes.
For more detailed information please ask our customer service.

SMW-AUTOBLOK Type			BP-D 220 BP-M 220		BP-D 260 BP-M 260			BP-D 320 BP-M 320		
Mounting			Z170	A6	Z220	A6	A8	Z300	A8	A11
	A	mm	220		262			320		
	Bf/BA	H6 mm	170	106.375	220	106.375	139.719	300	139.719	196.869
	C	mm	133.4		171.4			235		
	CA	mm	-	-	-	133.4	-	-	171.4	-
	D	mm	13.5		17	13.5	17	21		
	E	mm	72		88			115		
	Fmax	mm	M60 x 1.5		M75 x 2			M102 x 2		
	G	mm	61		76			102.5		
	Hf/HA	mm	97.5	109.5	114	149	128	114	149	130
	K	mm	52		66			95		
	L	mm	79.5		92			88		
	M	mm	M54 x 1.5		M68 x 2			M98 x 2		
	N	H8 mm	8		10			10		
	P	mm	6.5		8.5			8.5		
	Q	mm	12.5		16.5			16.5		
	R	H7 mm	59		76			108		
Chuck open	R1	mm	109		131			159		
	S	mm	63		81			113		
	T	mm	23.5		22			29		
Jaw stroke	U	mm	4.3		5			5		
	V	mm	7.75		6			9.5		
	W	mm	12		14			16.5		
	X1	mm	15.5		22			21		
	Yf/YA	mm	5	17	5	40	19	5	40	21
Max. / min.	Z	mm	16 / 0		19 / 0			19 / 0		
	a	mm	5.7		9.7			9.7		
BP-D Serration	d	inch	1/16" x 90°		1/16" x 90°			1/16" x 90°		
BP-M Serration	d	mm	1.5 x 60°		1.5 x 60°			1.5 x 60°		
	e	mm	74.5		89			100.5		
	f	mm	17.5		12			19		
	g	mm	2.5		2.5			3.5		
	j	mm	34		35.22			35		
	k1	mm	10.5		12			12		
BP-D/BP-M	l1	mm	23 / 25		30			30		
Max. / min.	l2	mm	55.5 / 33		67 / 43			78 / 43		
BP-D/ BP-M	m	mm	M12		M12			M16		
BP-D	n	h8 mm	17		17			21		
BP-M	n	h8 mm	14		16			21		
	p	mm	80		102			100		
	q	mm	45		60			60		
	r	mm	M8		M10			M10		