

FRC-N

Compensating clamping
TONGUE & GROOVE

Lever chuck Ø 215 - 365 mm

- Pull-down to axial datum
- Spring loaded or fixed center
- proofline® chucks = fully sealed - low maintenance



Application/customer benefits

- Compensating clamping of shafts between centers, where the clamping diameter is not concentric to the workpiece axis
- The grip force of the chuck supplies the torque necessary to machine the workpiece and pulls it down to the axial datum (center point / axial stop)
- Due to its high rigidity against torsion the chuck is ideal for turning as well as for milling operations

Technical features

- For O.D. clamping only
- Compensating clamping with large compensating stroke
- TONGUE & GROOVE base jaws
- Pull down to axial datum
- Centrifugal force compensation
- Permanent grease lubrication
- High rigidity against torsion
- Center point adjustable
- **proofline® chucks** = fully sealed - low maintenance

Standard equipment

3-jaw chuck without centering insert
Mounting bolts

Ordering example

Lever chuck FRC-N 215 A6

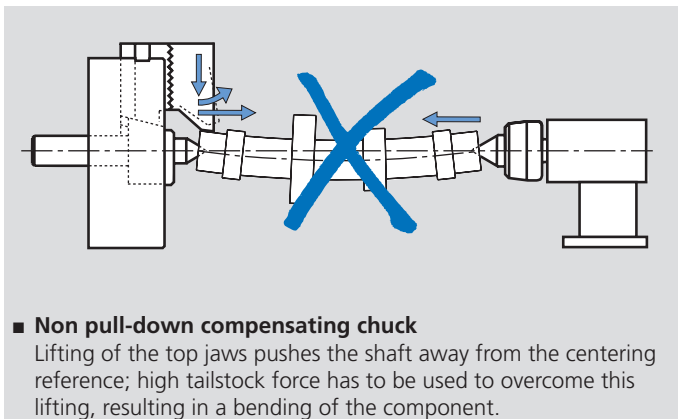

■ Non pull-down compensating chuck

Lifting of the top jaws pushes the shaft away from the centering reference; high tailstock force has to be used to overcome this lifting, resulting in a bending of the component.

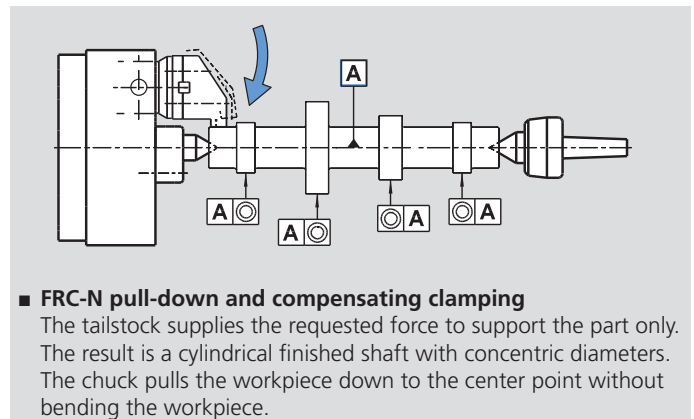

■ FRC-N pull-down and compensating clamping

The tailstock supplies the requested force to support the part only. The result is a cylindrical finished shaft with concentric diameters. The chuck pulls the workpiece down to the center point without bending the workpiece.

Technical data

SMW-AUTOBLOK Type		FRC-N 215	FRC-N 285	FRC-N 365
Angular jaw stroke U°	deg.	6°	6°	6°
Radial jaw stroke at distance h	mm	6.3	7.3	8.4
Wedge stroke	mm	22	26	31
Compensation (on the dia.) at distance h	mm	±1.5	±2	±2.5
Max. draw pull	kN	45	70	110
Max. gripping force at distance h	kN	100	150	240
Max. speed	r.p.m.	4500	3500	2500
Weight (plain back without top jaws)	kg	30	62	120
Moment of inertia*	kg·m ²	0.17	0.65	2
Standard fixed center	Id. No.	81732141	81732841	81733641
Standard spring loaded center	Id. No.	81722141	81722841	81723641
Recommended actuating cylinders	Type	SIN-S 100 - 125	125 SIN-S 125 -150	SIN-S 150 - 200
Id. No. FRC-N		77817821	77817828	77817836

* The above maximum speed is allowed with standard weight / height top jaws and applying the full draw pull only. For more information please contact SMW-AUTOBLOK.

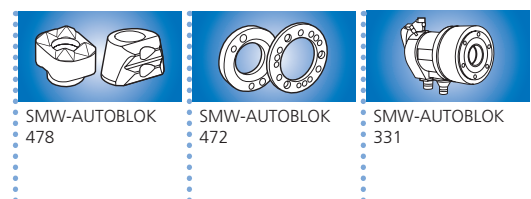

Lever chuck Ø 215 - 365 mm

FRC-N

- Pull-down to axial datum
- Spring loaded or fixed center
- proofline® chucks = fully sealed - low maintenance

Compensating clamping
TONGUE & GROOVE

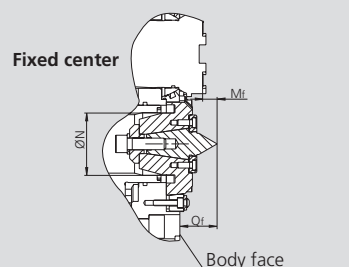
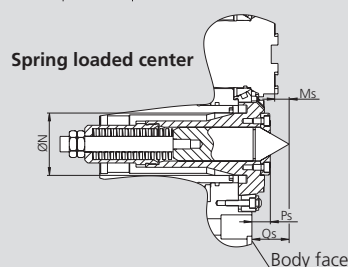
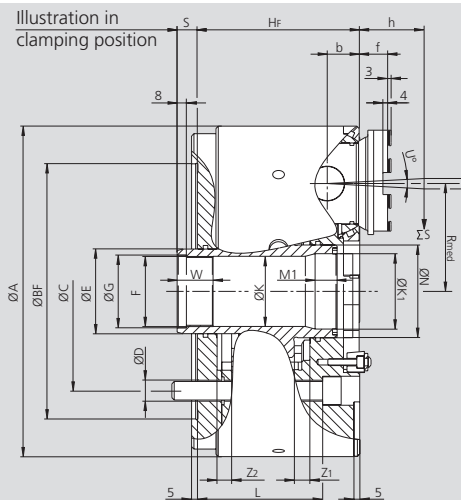
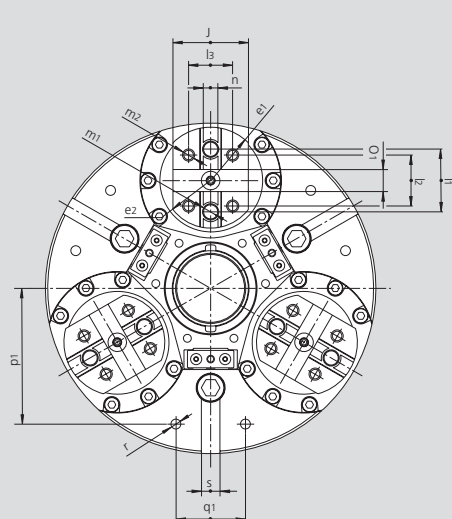

Subject to technical changes.
For more detailed information please ask our customer service.

SMW-AUTOBLOK Type		FRC-N 215	FRC-N 285	FRC-N 365	
	A	mm	215	285	365
	BF H6	mm	170	220	300
	C	mm	133.4	171.4	235
	D	mm	13.5	17	21
	E	mm	50	73	79
	F	mm	M42 x 1.5	M60 x 1.5	M68 x 2
	G H8	mm	43	61	69
	Hf	mm	120	140	168
Through-hole	K	mm	40	57	60.5
	Ø K1/ depth M1	mm	40	62 / 45	75 / 23.8
	L	mm	95	108	123
	N H8	mm	52	80	90
	Mf	mm	14.5	14.6	21.7
	Qf	mm	32.5	38.6	42.7
	Ms	mm	13.8	14.4	19.9
	Ps	mm	21	19	21.5
	Qs	mm	31.8	38.4	40.9
	Rmed	mm	67	93	120
Middle stroke = Clamping position	S	mm	15.4	17.5	24.8
Min. / max.	S	mm	4 / 26	4 / 30	9 / 40
Angular jaw movement	U°	deg.	6°	6°	6°
Radial stroke at distance h ⁽¹⁾	U	mm	6.3	7.3	8.4
	W	mm	30	31	30
	Z1	mm	11.4	13.5	15.8
	Z2	mm	10.6	12.5	15.2
	b	mm	22	28	34
	e1	mm	37.5	46	50
	e2	mm	33	41	50
	f	mm	18	24	21
Reference height	h	mm	38	42	46
	j	mm	55	65	70
	l1	mm	38	54	63.5
	l2	mm	32	44	48
	l3	mm	32	38	48
Thread / depth	m1	mm	M12 / 16	M16 / 20	M16 / 20
Thread / depth	m2	mm	M10 / 14	M12 / 19	M12 / 19
	n h8	mm	7.94	12.7	12.7
	o1 H7	mm	12.68	19.03	19.03
	p1	mm	80	117	150
	q1	mm	45	60	80
Thread / depth	r	mm	M8 / 17	M10 / 19	M12 / 22
	s H8	mm	16	16	20

⁽¹⁾ Calculated at **h** distance from the chuck's face (where normally the clamping takes place).