

Application/customer benefits

- Clamping and positioning of short bar material.
- Positioning of shaft type components in automatic production cycle.

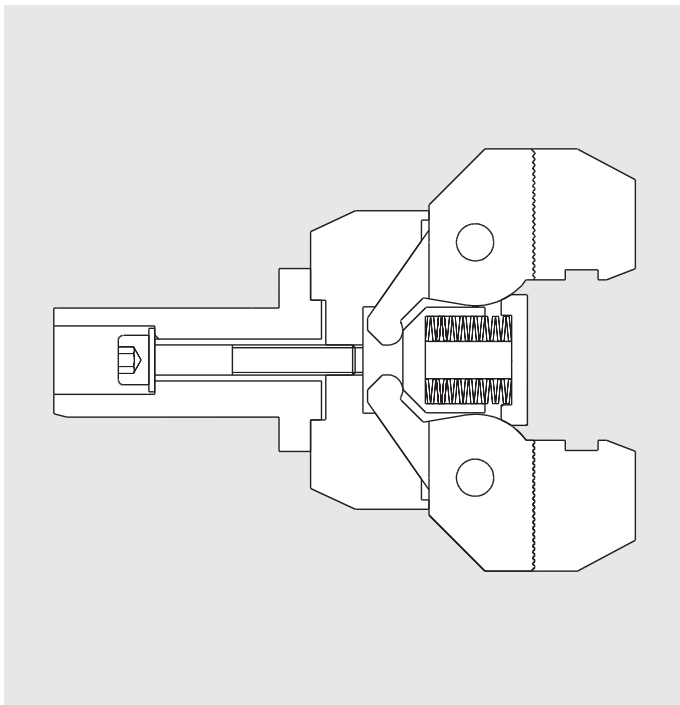

Profitability

- Direct mounting to the turret of the lathe - actuation device is not necessary.
- Suitable to all tool mounting systems.
- Only one tool place of turret is required.
- Simple production of special jaws for special bar profiles.
- High flexibility at small quantities.
- Simple set-up.
- Simple, safe spring pre-loading of jaws.
- Hardened / quenched clamping arms ensure long service life.

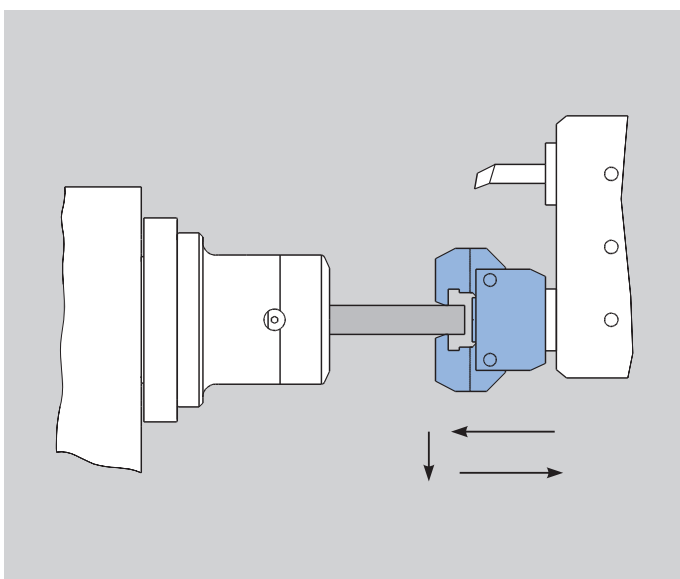

Function

- Move bar pulling chuck GF onto the workpiece with the turret in Z-axis.
- The bar pulling chuck is clamping self acting via spring pre-loading.
- Open collet chuck.
- Move turret to position workpiece.
- Close collet chuck.
- Remove bar pulling chuck GF in Z-axis.

■ Main dimensions and technical data

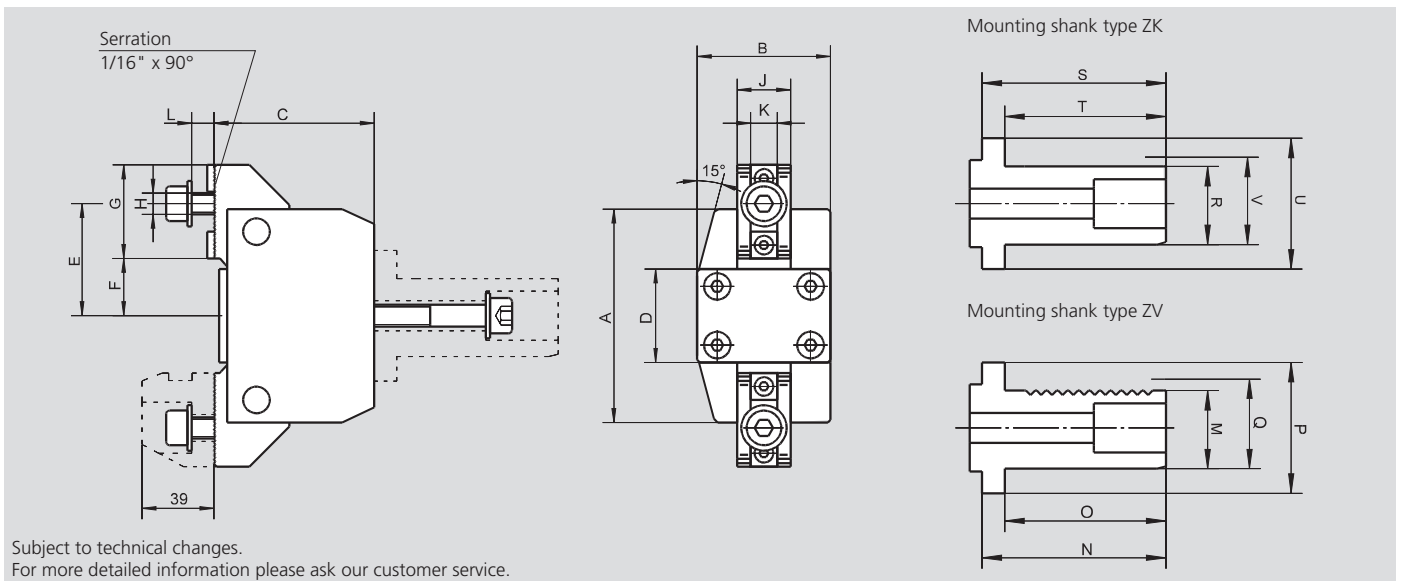

Chuck type	A	B	C	D	E	F	G	H	J	K	L	Stroke per jaw	Gripping force (daN)
GF 80	80	50	60	35	42	21.5	35	M8	20	10	8	4	250
Mounting shank	M	N	O	P	Q	R	S	T	U	V			
ZV 20	18	47	35	32	20								
ZV 30	27	63	55	48	30								
ZV 40	36	71	63	48	40								
ZV 50	45	86	78	58	50								
ZK 30						26	63	55	48	30			
ZK 40						35	71	63	48	40			
ZK 50						44	86	78	58	50			

Ordering review bar pulling chuck GF 80

Standard supply range: Bar pulling chuck GF 80 with / without shank, mounting bolts, without jaws

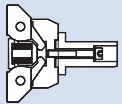

Type	GF 80	GF 80-ZV 20	GF 80-ZV 30	GF 80-ZV 40	GF 80-ZV 50	GF 80-ZK 30	GF 80-ZK 40	GF 80-ZK 50
Shank	without shank	ZV 20	ZV 30	ZV 40	ZV 50	ZK 30	ZK 40	ZK 50
Id. No.	010903	089614	089615	089616	089617	089618	089619	089620

Separate mounting shanks ZV/ZK

Mounting shanks type ZV DIN 69880 (serrated) / mounting shanks type ZK (with clamping area)

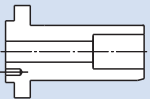

Shank Type	ZV 20	ZV 30	ZV 40	ZV 50	ZK 30	ZK 40	ZK 50
Id. No.	016339	012383	012384	012385	060088	060214	012389

Top jaws type GFB

Standard supply range: 1 set (= 2 pieces) clamping jaws without mounting bolts



Type	GFB 1	GFB 2	GFB 3	GFB 4	GFB 5
Clamping range (mm)	5 - 25	25 - 45	45 - 65	65 - 80	80 - 100
Id. No.	016348	016349	016350	016351	016352