

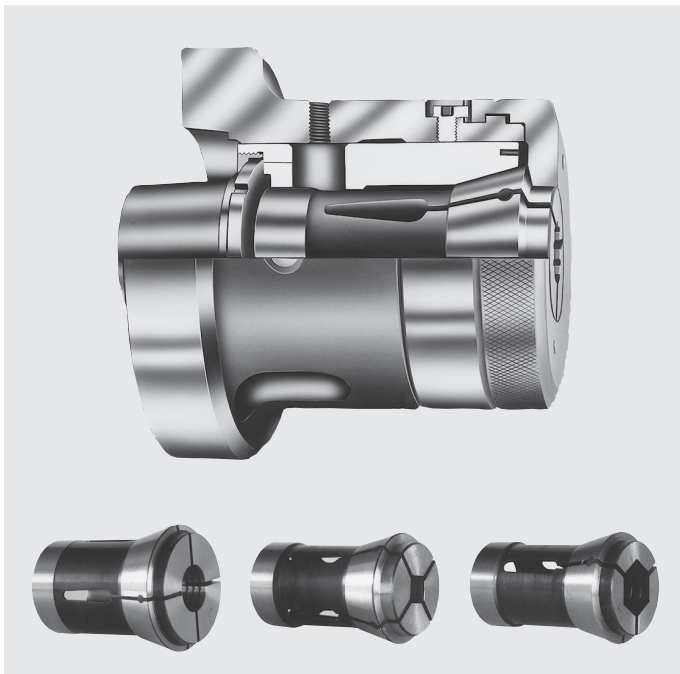

Application/customer benefits

- Efficient machining of bar material on automatic bar machines with bar feed.
- Less deformation of thin-walled components during clamping.
- Quick set-up by means of bayonet locking cap.
- For highest speeds.
- Clamping / unclamping of chuck during spindle rotation is possible.



Profitability

- Quick and simple installation to all lathes (alternating with 3-jaw chucks).
- Round, square and hexagonal material can be clamped by simply changing the collet.
- Cost effective by using standard collets DIN 6343 as well as standard Rubberflex and multi range collets.
- Collets for highest concentricity for special profiles, vulcanized, coated or ground to size are available on request.

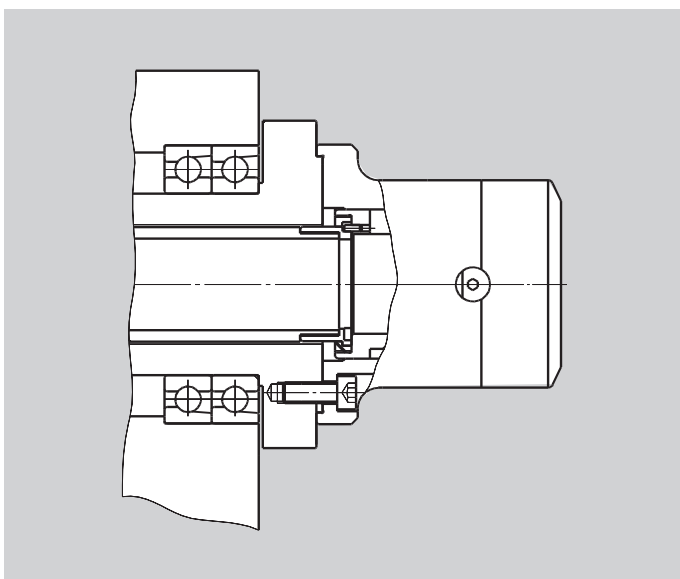

- Case hardened and ground chuck parts ensure long service life.
- Finish-machining of all parts in one set-up guarantees perfect concentricity.
- Direct mounting to the machine spindle ensures high concentricity.
- High operating reliability due to a minimum of parts.
- High axial positioning accuracy of the components by means of push type collet system.

Main dimensions and technical data

Attention: Chuck position „open“ (left end position) is situated with end stop in actuating cylinder.
Do not actuate chuck without cap nut mounted!
Remove pin dia. 3 for rotating ring nut for direct connection in thread dimension T.

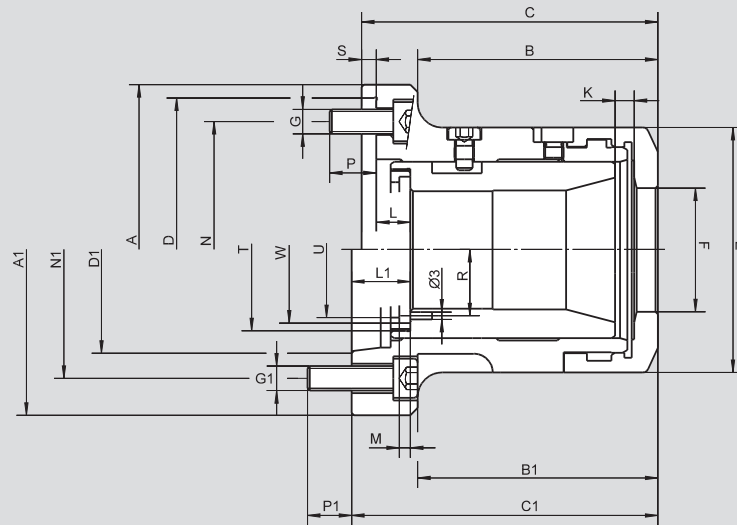

Subject to technical changes.
For more detailed information please ask our customer service.

SMW-AUTOBLOK Type		KSZ-MB 40			KSZ-MB 60				KSZ-MB 80
Mounting		Z140	A5	A6	Z170	Z220	A6	A8	Z220 / A8
Id. No.		088174	088180	088179	088175	088176	088178	088177	091209
	A h6	148	-	-	185	235	-	-	-
	A1 h6	-	135	170	-	-	170	220	220
	B	90.9	-	-	108.9	108.9	-	-	-
	B1	-	96.9	91.9	-	-	117.9	108.4	147
	C	113.9	-	-	138.9	140.9	-	-	-
	C1	-	123.9	123.9	-	-	144.9	145.9	176.5
Center mounting	D	140	-	-	170	220	-	-	-
Short taper mounting according to DIN 55026	D1	-	A5	A6	-	-	A6	A8	A8
	E	102	102	102	130	130	130	130	156
	F	51	51	51	74	74	74	74	95
	G	3 x M10	-	-	6 x M12	6 x M16	-	-	-
	G1	-	4 x M10	4 x M12	-	-	4 x M12	4 x M16	6 x M16
	K_{max.}	7.5	7.5	7.5	7.5	7.5	7.5	7.5	7.5
	L	8.5	-	-	14.0	16.0	-	-	-
	L1	-	24.5	24.5	-	-	26.0	27.0	41
	M	4.5	4.5	4.5	4.5	4.5	4.5	4.5	6.0
	N	104.8	-	-	133.4	171.4	-	-	-
	N1	-	104.8	133.4	-	-	133.4	171.4	171.4
	P	18	-	-	14	20	-	-	-
	P1	-	14	14.5	-	-	16	16	27.5
	R	28	28	28	39.5	39.5	39.5	39.5	51
	S	6	-	-	6	6	-	-	-
Pressure sleeve thread / thread depth	T	M66 x 1.5 / 8			M90 x 1.5 / 8				M114 x 2 / 11
	U	54			77				99
	W	62.5			83				107
Max. speed	r.p.m.	6000	6000	6000	5000	5000	5000	5000	4000
Max. actuating force	daN	2500	2500	2500	3000	3000	3000	3000	3500
Max. gripping force	daN	5400	5400	5400	6500	6500	6500	6500	7300
Weight without collets	kg	6.1	7.7	7.8	13.6	14.2	14.1	18.1	20.8
Rec. actuating cylinders	Type	VNK-T2 102-46			VNK-T2 150-67				VNK-T2 200-86
Speed	r.p.m.	7000			5500				4000



KSZ-MB

Collet chuck

■ Ordering review

Supply range: Chuck and mounting bolts

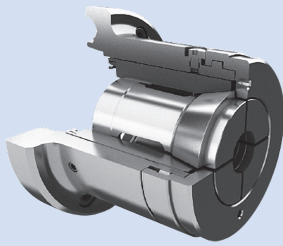

Spindle mounting	Size	KSZ-MB 40	KSZ-MB 60	KSZ-MB 80 - 193 E
Centering rim standard		Z140 088174	Z170 088175	Z220* 091209*
Centering rim large			Z220 088176	
A 05		088180		
A 06		088179	088178	
A 08			088177	091209*

* Attention: KSZ-MB 80-193E with standard centering rim (Id. No. 091209) has outside centering 220 mm (and also inside taper A8).

Accessories for KSZ-MB

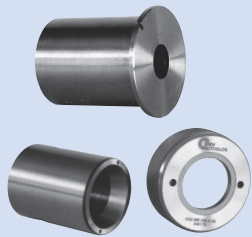

Accessories	Size	KSZ-MB 40	KSZ-MB 60	KSZ-MB 80
Blank adapter		0363960	0360810	
Reduction for smaller collets (comprising pressure sleeve and cap nut)		KSZ-MB size 40 to size 26 0360720 / 0361792	KSZ-MB size 60 to size 40 0360121 / 0361360	KSZ-MB size 80 to size 40 0362082 / 0360135
				KSZ-MB size 80 to size 60 0362081 / 0360134

Collets for KSZ-MB 40

Steel collets DIN 6343 series 173 E

ROUND*

Ø	3	3.5	4	4.5	5	5.5	6	6.5	7	7.5	8	8.5	9
Id. No.	012961	012962	012963	012964	012965	012966	012967	012968	012969	012970	012971	012972	012973
Ø	9.5	10	10.5	11	11.5	12	12.5	13	13.5	14	14.5	15	15.5
Id. No.	012974	012975	012976	012977	012978	012979	012980	012981	012982	012983	012984	012985	012986
Ø	16	16.5	17	17.5	18	18.5	19	19.5	20	20.5	21	21.5	22
Id. No.	012987	012988	012989	012990	012991	012992	012993	012994	012995	012996	012997	012998	012999
Ø	22.5	23	23.5	24	24.5	25	25.5	26	26.5	27	27.5	28	28.5
Id. No.	013000	013001	013002	013003	013004	013005	013006	013007	013008	013009	013010	013011	013012
Ø	29	29.5	30	30.5	31	31.5	32	32.5	33	33.5	34	34.5	35
Id. No.	013013	013014	013015	013016	013017	013018	013019	013020	013021	013022	013023	013024	013025
Ø	35.5	36	36.5	37	37.5	38	38.5	39	39.5	40	40.5	41	41.5
Id. No.	013026	013027	013028	013029	013030	013031	013032	013033	013034	013035	013036	013037	013038
Ø	42												
Id. No.	013039												

HEXAGONAL**

Hexagon	6	7	8	9	10	11	12	13	14	15	16	17	19
Id. No.	013040	013041	013042	013043	013044	013045	013046	013047	013048	013049	013050	013051	013052
Hexagon	20	21	22	24	26	27	28	30	31	32	36		
Id. No.	016428	016429	013053	013054	016430	013055	016431	013056	016432	013057	013058		

SQUARE**

Square	6	7	8	9	10	11	12	13	14	15	16	18	20
Id. No.	013059	013060	013061	013062	013063	013064	013065	013066	013067	013068	013069	013070	013071
Square	22	25	28										
Id. No.	013072	013073	013074										

Rubberflex collets series 36 (recommended for raw part clamping)

ROUND

Ø	7-9	9-11	11-13	13-15	15-17	17-19	19-21	21-23	23-25	25-27	27-29	29-31	31-33
Id. No.	013076	013077	013078	013079	013080	013081	013082	013093	013083	013084	013085	013086	013087
Ø	33-35	35-37	37-39	39-41	41-43								
Id. No.	013088	013089	013090	013091	013092								

* Concentricity according to DIN 6343.

** Concentricity has to be agreed.

Collets for KSZ-MB 60

Steel collets DIN 6343 series 185 E

ROUND*

∅	4	5	6	7	8	9	10	11	12	13	14	15	16
Id. No.	013112	013113	013114	013115	013116	013117	013118	013119	013120	013121	013122	013123	013124
∅	17	18	19	20	21	22	23	24	25	26	27	28	29
Id. No.	013125	013126	013127	013128	013129	013130	013131	013132	013133	016434	013134	013135	013136
∅	30	31	32	33	34	35	36	37	38	39	40	41	42
Id. No.	013137	013138	013139	013140	013141	013142	013143	013144	016435	013145	013146	013147	013148
∅	43	44	45	46	47	48	49	50	51	52	53	54	55
Id. No.	013149	013150	013151	013152	013153	013154	013155	013156	013157	013158	013159	013160	013161
∅	56	57	58	59	60								
Id. No.	013162	013163	013164	013165	013166								

HEXAGONAL**

⬡	8	9	10	11	12	13	14	15	16	17	19	22	24
Id. No.	013167	013168	013169	013170	013171	013172	013173	013174	013175	013176	013177	013178	013179
⬡	27	30	32	36	41	50							
Id. No.	013180	013181	013182	013183	019312	019592							

SQUARE**

□	7	8	9	10	11	12	13	14	15	16	17	18	20
Id. No.	013184	013185	013186	013187	013188	013189	013190	013191	013192	013193	019110	013194	013195
□	22	25	28	30	32	35	36	40					
Id. No.	013196	013197	013198	013199	013200	019111	013201	017800					

Rubberflex collets series 52 (recommended for raw part clamping)

ROUND

∅	35-37	37-39	39-41	41-43	43-45	45-47	47-49	49-51	51-53	53-55	55-57	57-59	59-61
Id. No.	013203	013204	013205	013206	013207	013208	013209	013210	013211	013212	013213	013214	013215

Collets for KSZ-MB 80

Steel collets DIN 6343 series 193 E

ROUND*

∅	20	21	22	23	24	25	26	27	28	29	30	31	32
Id. No.	013237	013238	013239	013240	013241	013242	013243	013244	013245	013246	013247	013248	013249
∅	33	34	35	36	37	38	39	40	41	42	43	44	45
Id. No.	013250	013251	013252	013253	013254	013255	013256	013257	013258	013259	013260	013261	013262
∅	46	47	48	49	50	51	52	53	54	55	56	57	58
Id. No.	013263	013264	013265	013266	013267	013268	013269	013270	013271	013272	013273	013274	013275
∅	59	60	61	62	63	64	65	66	67	68	69	70	71
Id. No.	013276	013277	013278	013279	013280	013281	013282	013283	013284	013285	013286	013287	013288
∅	72	73	74	75	76	77	78	79	80				
Id. No.	013289	013290	013291	013292	013293	013294	013295	013296	013297				

Further collets are available on request.

* Concentricity according to DIN 6343.

** Concentricity has to be agreed.